



**TUBIFICIO  
LOMBARDO**

info@tubilomb.it  
tubificio.lombardo.it



# QUICKLOCK SYSTEM

MECHANICAL JOINTED  
PIPING



# CONTENTS

**TUBIFICIO LOMBARDO AT A GLANCE** 4

**1. QUICKLOCK PIPES & COUPLINGS:**

TYPE C UNIVERSAL	6
TYPE B	8
TYPE C-SLURRY	8
TYPE C-GROUT	10
TYPE C-SNOW	12
ROLL GROOVED	14
TYPE D SWE	16
TYPE B AUS	16
THREADED	17
SPHERICAL	18



## **2. QUICKLOCK FITTINGS**

GROOVED END TO BE WELDED	19
ELBOW	20
TEE	22
CROSS, DISTRIBUTOR	23
REDUCER, AXIAL COMPENSATOR	24
CAP - SOCKET	25
LATERAL TEE, HOSE SPIGOT	26
FLANGED OUTLET, FLANGED BELLOWS, LUBRICANT	27

<b>3. VALVES</b>	28
------------------	----

<b>4. THE QUICKLOCK SYSTEM</b>	30
--------------------------------	----

<b>5. DESIGN DATA, GASKETS</b>	38
--------------------------------	----

<b>6. INSTALLATION INSTRUCTIONS</b>	47
-------------------------------------	----

# TUBIFICIO LOMBARDO AT A GLANCE

## TUBIFICIO LOMBARDO SRL

Established in 1994, is one of the European leading enterprises of mechanical jointed piping. The advanced technological level of the facilities, the quality of the products and the worldwide experience in the most challenging projects make of **Tubificio Lombardo** a greatly considered and reliable company.



**LIGHT. EFFICIENT.  
RELIABLE.**







# QUICKLOCK PIPE TYPE C - UNIVERSAL

WATER, SEWAGE, AIR APPLICATION - TUNNELING, MINING, INDUSTRIAL BUSINESS, SHIPBUILDING.

- Trasporto acqua, liquami e aria - Utilizzo in galleria, industria mineraria, attività industriali, costruzioni navali.
- Wasser, Kühlwasser, Schmutzwasser, Druckluft – Tunnelbau, Bergbau, Industriebau, Schiffbau.
- Transport et adduction d'eau, eaux usées, eaux chargées, air – Tunnel, mines, carrières, BTP, chantiers navals.
- Agua, aguas residuales, aplicación de aire - Construcción de un túnel, minería, negocio industrial, construcción naval.

## Pipes Type C - Standard cut grooved dimensions

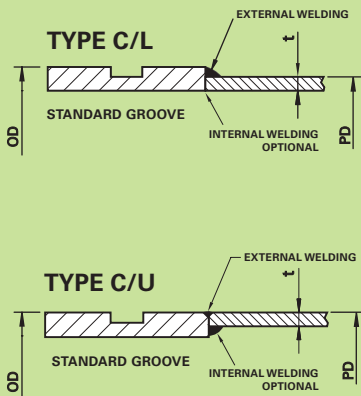

Nominal size In / DN	O.D. inches mm	P.D. inches mm	Nominal Pressure psi / bar	t inches mm	Steel grade US ** EU	Grooved ends type	Black pipe approx. weight 6 m lbs / Kg *
						Groove	
2" ✓ 50	2.375 60.3	2.375 60.3	500 34	0.060 1.5	Grade B S235	C/U standard	29.8 13.5
2 1/2" ✓ 65	3.000 76.1	70	500 34	0.060 1.5	Grade B S235	C/L standard	35.1 15.9
3" ✓ 80	3.500 88.9	80	500 34	0.060 1.5	Grade B S235	C/L standard	40.0 18.1
4" ✓ 100	4.500 114.3	4.250 108	500 34	0.060 1.5	Grade B S235	C/L standard	54.3 24.6
4" ✓ 100	4.500 114.3	4.250 108	500 34	0.080 2	Grade B S235	C/L standard	71 32.2
5" ✓ 125	5.500 139.7	130	450 31	0.080 2	Grade B S235	C/L standard	86.4 39.2
6" ✓ 150	6.625 168.3	6.250 159	300 21	0.060 1.5	Grade B S235	C/L standard	80.9 36.7
6" ✓ 150	6.625 168.3	6.250 159	360 25	0.080 2	Grade B S235	C/L standard	106 48.1
6" ✓ 150	6.625 168.3	6.250 159	450 31	0.100 2.5	Grade B S235	C/L standard	131 59.4
8" ✓ 200	8.625 219.1	8.000 203	450 31	0.119 3	Grade B S235	C/L standard	204.6 92.8
8" ✓ 200	8.625 219.1	8.625 219.1	450 31	0.119 3	Grade B S235	C/U standard	217 98.4
10" ✓ 250	10.750 273	10.750 273	300 21	0.156 4	Grade B S235	C/U standard	360.5 163.5
10" ✓ 250	10.750 273	10.750 273	450 31	0.156 4	Grade B S235	C/U standard	360.5 163.5
12" ✓ 300	12.750 323.9	12.750 323.9	300 21	0.156 4	Grade B S235	C/U standard	426.6 193.5
14" ✓ 350	14.000 355.6	14.000 355.6	300 21	0.196 5	Grade B S235	C/U standard	581 263.5
16" ✓ 400	16.000 406.4	16.000 406.4	300 21	0.196 5	Grade B S235	C/U standard	668 303
18" ✓ 450	18.000 457.2	18.000 457.2	300 21	0.196 5	Grade B S235	C/U standard	756.2 343
20" ✓ 500	20.000 508	20.000 508	300 21	0.250 6.3	Grade B S235	C/U standard	1069.3 485

✓ - Most Popular.

\* - Hot dip galvanized pipe weight +10%.

**TECHNICAL NOTES:**

Pipes are bundled in hexagonal rigid bundles to ease unloading, handling and safety at jobsite.  
 Pipes can be manufactured with any thickness available on the market, options indicated are the lower to guarantee pressure rated in application with couplings proposed.  
 Standard lengths are 6 m / 19 ft 8,2 in for truck and 5,85 m / 19 ft 2,3 in for container.  
 Whenever pipes are placed in trench it is imperative making hydraulic test before covering with earth.

**PIPE SURFACE TREATMENT OPTIONS:**

- 1) Black, untreated. Suitable for temporary pipeline.
- 2) Hot dip galvanized EN1461:2009 lead free. Suitable for a long lasting protection from corrosion.
- 3) External light painting with water based liquid coating. Suitable when short terms protection it is acceptable.
- 4) External anticorrosion coating: layer polyethylene, layer polypropylene, fusion bonded epoxy, dual layer fusion bonded epoxy.  
 Internal coating: liquid paint, flow coat. These external and internal coatings are available only in case of large projects.



**STANDARD Couplings - Ductile Iron**

Nominal size In / DN	Groove size In / mm	Nominal Pressure psi / bar	Approx. Dimensions			Groove	Approx. Weight lbs / Kg
			A in / mm	B in / mm	C in / mm		
2" 50	2.375 60.3	500 34	3.27 83	4.92 125	1.74 44	standard	1.7 0.8
2 1/2" 65	3.000 76.1	500 34	3.94 100	5.71 145	1.78 45	standard	1.9 0.9
3" 80	3.500 88.9	500 34	4.53 115	6.30 160	1.78 45	standard	2.9 1.3
4" 100	4.500 114.3	500 34	5.80 147	8.03 204	2.13 54	standard	4.1 1.9
4" 100	4.500 114.3	500 34	5.80 147	8.03 204	2.13 54	standard	4.1 1.9
5" 125	5.500 139.7	450 31	6.80 173	9.59 244	2.13 54	standard	6.3 2.9
6" 150	6.625 168.3	450 31	8.00 203	11.07 281	2.28 58	standard	7 3.2
6" 150	6.625 168.3	450 31	8.00 203	11.07 281	2.28 58	standard	7 3.2
6" 150	6.625 168.3	450 31	8.00 203	11.07 281	2.28 58	standard	7 3.2
8" 200	8.625 219.1	450 31	10.34 263	13.97 355	2.32 59	standard	12.4 5.6
8" 200	8.625 219.1	450 31	10.34 263	13.97 355	2.32 59	standard	12.4 5.6
10" 250	10.750 273	300 21	13.27 337	16.00 406	2.56 65	standard	24.0 10.9
10" 250	10.750 273	450 31	13.63 346	17.13 435	2.63 67	HP couplings	31.1 14.1
12" 300	12.750 323.9	300 21	14.96 378	18.31 465	2.56 65	standard	27.8 12.6
14" 350	14.000 355.6	300 21	15.83 402	19.41 493	2.83 72	standard	39.2 17.8
16" 400	16.000 406.4	300 21	18.03 458	21.54 547	2.85 72	standard	45.0 20.4
18" 450	18.000 457.2	300 21	19.88 505	23.54 598	3.07 78	standard	64.4 29.2
20" 500	20.000 508	300 21	21.65 550	25.51 648	3.07 78	standard	74,8 34.0

\*\* - US Steel grade is for reference only.

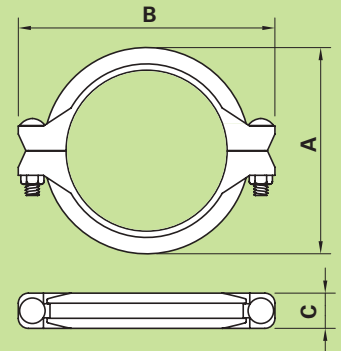

**STANDARD LOW PRESSURE COUPLINGS**  
 Diam. 1" - 24" PN21 PSI 300

**STANDARD MEDIUM PRESSURE COUPLINGS**  
 Diam. 1" - 4" PN34 PSI 500  
 Diam. 5" - 12" PN31 PSI 450  
 Diam. 14" - 24" PN21 PSI 300

**HIGH PRESSURE COUPLINGS**  
 Diam. 2" - 8" PN80 PSI 1162  
 Diam. 10" - 12" PN55 PSI 800

*From Diam. 14" couplings can be made of 3 or more parts*



# QUICKLOCK PIPE TYPE B

WATER APPLICATION - TUNNELING AND MINING BUSINESS.

- Trasporto d' acqua - Utilizzo in gallerie e industria mineraria.
- Wasser, Kühlwasser - Tunnelbau, Bergbau.
- Transport et adduction d'eau, eaux chargées – Tunnel, mines.
- Aplicación de agua - Construcción de un túnel, minería.

## Pipes Type B - Standard Cut grooved dimensions

Nominal size In / DN	O.D. inches mm	P.D. inches mm	Nominal Pressure psi / bar	t inches mm	Steel grade US ** EU	Grooved ends type	Black pipe approx. weight 6 m lbs / Kg *	
						Groove		
2 1/2" 65	3.000 76.1	70	500 34	0.060 1.5	Grade B S235	B standard	34.4 15.6	
3" 80	3.500 88.9	80	500 34	0.060 1.5	Grade B S235	B standard	39.3 17.8	
4" 100	4.500 114.3	4.250 108	500 34	0.060 1.5	Grade B S235	B standard	53.2 24.1	
4" 100	4.500 114.3	4.250 108	500 34	0.080 2	Grade B S235	B standard	70.1 31.8	
5" 125	5.500 139.7	130	450 31	0.080 2	Grade B S235	B standard	85.1 38.6	
6" 150	6.625 168.3	6.250 159	300 21	0.060 1.5	Grade B S235	B standard	78.7 35.7	
6" 150	6.625 168.3	6.250 159	360 25	0.080 2	Grade B S235	B standard	104 47.2	
6" 150	6.625 168.3	6.250 159	450 31	0.100 2.5	Grade B S235	B standard	129.2 58.6	

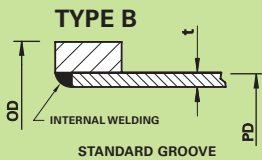

# QUICKLOCK PIPE TYPE C - SLURRY

SLURRY APPLICATION - TUNNELING AND MINING BUSINESS.

- Drenaggio dei fanghi – Utilizzo in galleria, industria mineraria e attività industriali.
- Förder- Speisekreislauf – Tunnelbau, Bergbau.
- Drainage des sols – Tunnel, mines, carriere, BTP, chantiers navals.
- Aplicación de lechada - Construcción de un túnel, minería.

## Pipes Type C - Standard cut grooved dimensions

Nominal size In / DN	O.D. inches mm	P.D. inches mm	Nominal Pressure psi / bar	t inches mm	Steel grade US ** EU	Grooved ends type	Black pipe approx. weight 6 m lbs / Kg *	
						Groove		
8" 200	8.625 219.1	8.000 203	450 31	0.219 5.6	X52 S355	C/L2 standard	374.8 170	
10" 250	12.750 323.9	10.750 273	300 21	0.250 6.3	X52 S355	C/L2 standard	595.3 270	
12" 300	14.000 355.6	12.750 323.9	300 21	0.271 7.1	X52 S355	C/L2 standard	771.6 350	
14" 350	14.842 377	14.000 355.6	300 21	0.271 7.1	X52 S355	C/L2 standard	837.8 380	
16" 400	16.772 426	16.000 406.4	300 21	0.271 7.1	X52 S355	C/L2 standard	956.8 434	
18" 450	18.898 480	18.000 457.2	300 21	0.337 8.6	X52 S355	C/L2 standard	1300.7 590	
20" 500	20.866 530	20.000 508	300 21	0.375 9.5	X52 S355	C/L2 standard	1591.7 722	

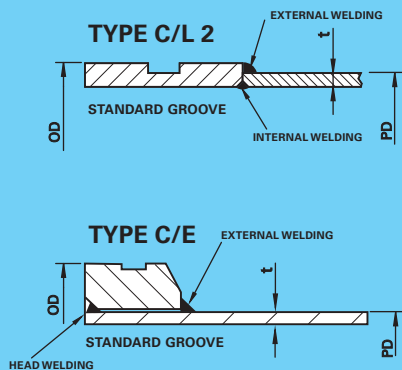
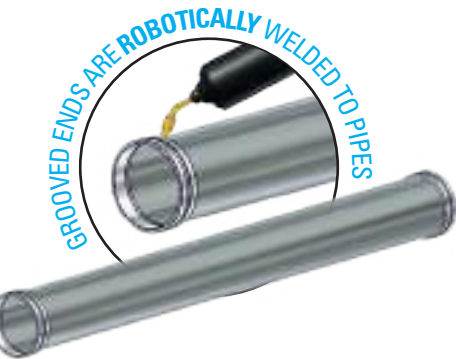

✓ - Most Popular.

\* - Hot dip galvanized pipe weight +10%.

**TECHNICAL NOTES:**

Pipes are bundled in hexagonal rigid bundles to ease unloading, handling and safety at jobsite.  
 Pipes can be manufactured with any thickness available on the market, options indicated are the lower to guarantee pressure rated in application with couplings proposed.  
 Standard lengths are 6 m / 19 ft 8,2 in for truck and 5,85 m / 19 ft 2,3 in for container.  
 Pipes are always longitudinally welded, never spirally welded; such solution in combination with special grooved design limits fluid turbulence.

**PIPE SURFACE TREATMENT OPTIONS:**

- 1) Black, untreated. Suitable for temporary pipeline.
- 2) Hot dip galvanized EN1461:2009 lead free. Suitable for a long lasting protection from corrosion.
- 3) External light painting with water based liquid coating. Suitable when short terms protection it is acceptable.
- 4) External anticorrosion coating: layer polyethylene, layer polypropylene, fusion bonded epoxy, dual layer fusion bonded epoxy.  
 Internal coating: liquid paint, flow coat. These external and internal coatings are available only in case of large projects.



**STANDARD Couplings - Ductile Iron**

Nominal size In / DN	Groove size In / mm	Nominal Pressure psi / bar	Approx. Dimensions			Groove	Approx. Weight lbs / Kg
			A in / mm	B in / mm	C in / mm		
2 1/2" 65	3.000 76.1	500 34	3.94 100	5.71 145	1.78 45	standard	1.9 0.9
3" 80	3.500 88.9	500 34	4.53 115	6.30 160	1.78 45	standard	2.9 1.3
4" 100	4.500 114.3	500 34	5.80 147	8.03 204	2.13 54	standard	4.1 1.9
4" 100	4.500 114.3	500 34	5.80 147	8.03 204	2.13 54	standard	4.1 1.9
5" 125	5.500 139.7	450 31	6.80 173	9.59 244	2.13 54	standard	6.3 2.9
6" 150	6.625 168.3	450 31	8.00 203	11.07 281	2.28 58	standard	7 3.2
6" 150	6.625 168.3	450 31	8.00 203	11.07 281	2.28 58	standard	7 3.2
6" 150	6.625 168.3	450 31	8.00 203	11.07 281	2.28 58	standard	7 3.2

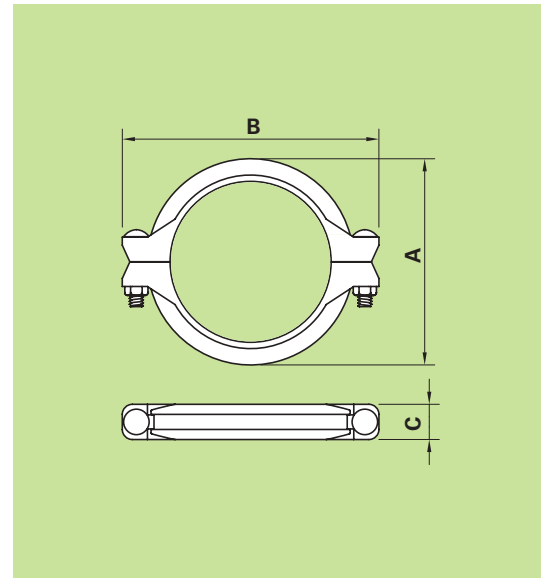

**HP or Standard Couplings - Ductile Iron**

Nominal size In / DN	Groove size In / mm	Nominal Pressure psi / bar	Approx. Dimensions			Groove	Approx. Weight lbs / Kg
			A in / mm	B in / mm	C in / mm		
8" 200	8.625 219.1	450 31	11.00 279	14.75 375	2.50 63	standard	20.8 9.4
12" 300	12.750 323.9	300 21	15.63 397	19.25 489	2.63 67	standard	27.8 12.6
14" 350	14.000 355.6	300 21	16.63 422	19.88 505	2.88 73	standard	35.6 16.1
14" 350	14.842 377	300 21	17.39 442	20.96 531	2.8 71	standard	39.2 17.8
16" 400	16.772 426	300 21	19.69 500	22.92 581	2.92 74	standard	56.7 25.7
18" 450	18.898 480	300 21	22.38 569	25.86 655	3.04 77	standard	77.2 35
20" 500	20.866 530	300 21	24.29 617	27.80 704	3.07 77	standard	91.7 41.6

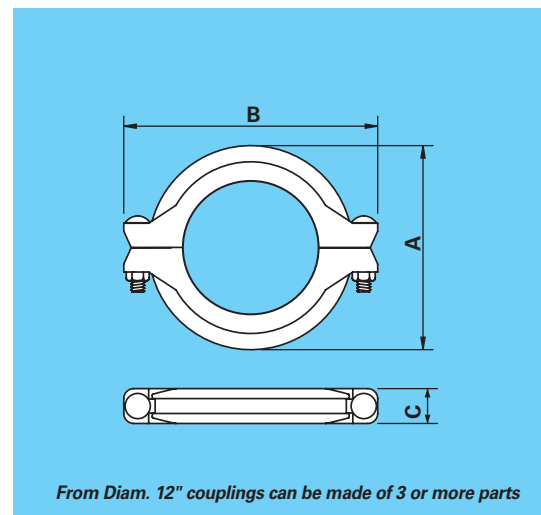

\*\* - US Steel grade is for reference only.

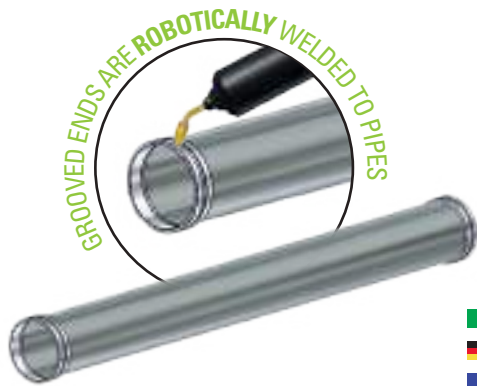

# QUICKLOCK PIPE TYPE C - GROUT

GROUTING AND BI-COMPONENT APPLICATION - TUNNELING AND MINING BUSINESS.

- Per iniezione di malte cementizie e bicomponenti - Utilizzo in galleria, industria mineraria, attività industriali.
- Zement- und Bi-Komponentenmörtel – Tunnelbau, Bergbau.
- Injection de produit cimenteux – Tunnel, mines, carrières, BTP.
- Rejuntado y aplicación del bi-componente - Construcción de un túnel, minería.

## Pipes Type C - Standard cut grooved dimensions \*\*\*

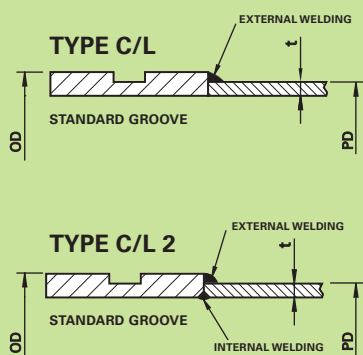

Nominal size In / DN	O.D. inches mm	P.D. inches mm	Nominal Pressure psi / bar	t inches mm	Steel grade US ** EU	Grooved ends type	Black pipe approx. weight 6 m lbs / Kg *
						Groove	
1 1/2" ✓ 40	2.375 60.3	1.900 48.3	1162 80	0.092 2.3	X52 S355	C/L standard	36.4 16.5
2" ✓ 50	3.000 76.1	2.375 60.3	1162 80	0.092 2.3	X52 S355	C/L standard	46.8 21.2
2 1/2" ✓ 65	3.500 88.9	3.000 76.1	1162 80	0.092 2.3	X52 S355	C/L standard	58.9 26.7
3" 80	4.500 114.3	3.500 88.9	1162 80	0.100 2.5	X52 S355	C/L2 standard	78 35.4
4" 100	4.500 114.3	4.250 108.0	1162 80	0.119 3	X52 S355	C/L2 standard	106.3 48.2
5" 125	5.500 139.7	130.0	1162 80	0.125 3.2	X52 S355	C/L2 standard	137.6 62.4
6" 150	6.625 168.3	6.250 159.0	1162 80	0.142 3.6	X52 S355	C/L2 standard	188.5 85.5
8" 200	8.625 219.1	8.000 203.0	800 55	0.188 4.8	X52 S355	C/L2 standard	324 147

\*\*\* NOMINAL PRESSURE CAN BE DOWNGRADED TO 64 BAR/930 PSI WITH S235/Grade B STEEL GRADE

## Pipes Type C - Lever cut grooved dimensions

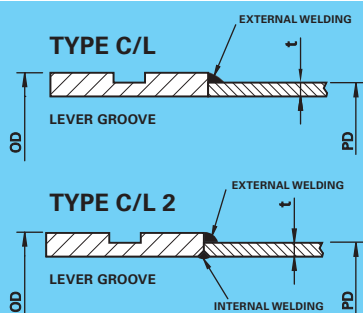

Nominal size In / DN	O.D. inches mm	P.D. inches mm	Nominal Pressure psi / bar	t inches mm	Steel grade US ** EU	Grooved ends type	Black pipe approx. weight 6 m lbs / Kg *
						Groove	
1 1/2" 40	2.375 60.3	1.900 48.3	1232 85	0.100 2.5	X52 S355	C/L LEVER	39.5 17.9
2" 50	2.875 73.0	2.375 60.3	1232 85	0.100 2.5	X52 S355	C/L LEVER	50 22.7
2 1/2" 65	3.500 88.9	3.000 76.1	1450 100	0.100 2.5	X52 S355	C/L LEVER	63.3 28.7
3 1/4" 85	3.820 97	3.500 88.9	1450 100	0.119 3	X52 S355	C/L2 LEVER	87 39.5

## Pipes Type C - TES cut grooved dimensions

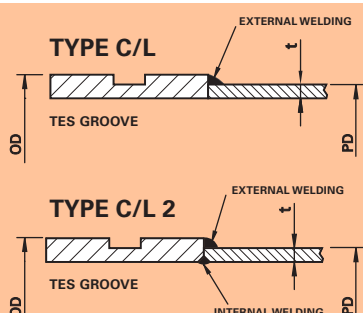

Nominal size In / DN	O.D. inches mm	P.D. inches mm	Nominal Pressure psi / bar	t inches mm	Steel grade US ** EU	Grooved ends type	Black pipe approx. weight 6 m lbs / Kg *
						Groove	
1 1/2" 40	2.375 60.3	1.900 48.3	2500 172	0.156 4	X52 / X56 S355N	C/L TES	60.6 27.5
2" 50	2.875 73	2.375 60.3	2500 172	0.156 4	X52 / X56 S355N	C/L TES	77.2 35
2 1/2" 65	3.500 88.9	1.000 76.1	2500 172	0.156 4	X52 / X56 S355N	C/L TES	98.4 44.6
3" 80	4.500 114.3	3.500 88.9	2500 172	0.196 5	X52 / X56 S355N	C/L2 TES	145 65.8

✓ - Most Popular.

\* - Hot dip galvanized pipe weight +10%.

**TECHNICAL NOTES:**

Pipes are bundled in hexagonal rigid bundles to ease unloading, handling and safety at jobsite.  
 Pipes can be manufactured with any thickness available on the market, options indicated are the lower to guarantee pressure rated in application with couplings proposed.  
 Standard lengths are 6 m / 19 ft 8,2 in for truck and 5,85 m / 19 ft 2,3 in for container.  
 Pipes are designed to limit fluid turbulence due to different internal diameters.

**PIPE SURFACE TREATMENT OPTIONS:**

- 1) Black, untreated. Suitable for temporary pipeline.
- 2) Hot dip galvanized EN1461:2009 lead free. Suitable for a long lasting protection from corrosion.
- 3) External light painting with water based liquid coating. Suitable when short terms protection it is acceptable.



**HP coupling - Ductile Iron**

Nominal size In / DN	Groove size In / mm	Nominal Pressure psi / bar	Approx. Dimensions			Groove	Approx. Weight lbs / Kg
			A in / mm	B in / mm	C in / mm		
2" 50	2.375 60.3	1162 80	3.63 92	5.88 149	1.88 48	standard	2.6 1.2
2 1/2" 65	3.000 76.1	1162 80	4.38 111	6.63 168	1.88 48	standard	3.2 1.5
3" 80	3.500 88.9	1162 80	5.00 127	7.13 181	1.88 48	standard	3.7 1.7
4" 100	4.500 114.3	1162 80	6.13 156	8.88 226	2.13 54	standard	6.7 3
4" 100	4.500 114.3	1162 80	6.13 156	8.88 226	2.13 54	standard	6.7 3
5" 125	5.500 139.7	1162 80	8.63 219	10.65 270	2.13 54	standard	10.0 4.5
6" 150	6.625 168.3	1162 80	8.63 219	11.88 302	2.13 54	standard	12.0 5.4
8" 200	8.625 219.1	800 55	11.00 279	14.75 375	2.50 63	standard	20.8 9.4

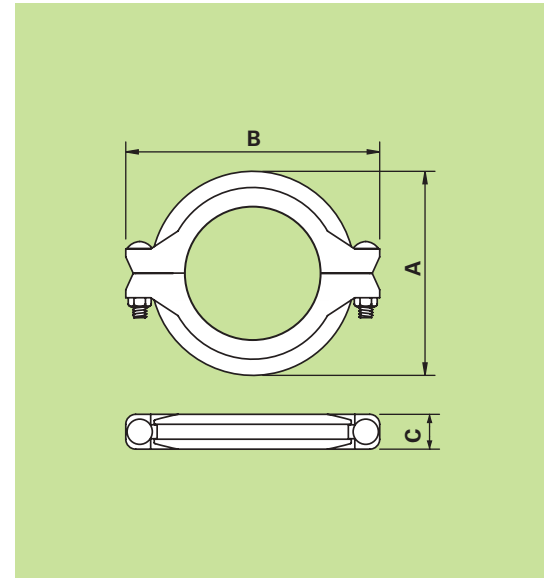

**LEVER coupling - Steel**

Nominal size In / DN	Groove size In / mm	Nominal Pressure psi / bar	Approx. Dimensions		Groove	Approx. Weight lbs / Kg	Most popular
			A in / mm	B in / mm			
2" 50	2.375 60.3	1232 85	4.13 105	5.75 146	LEVER	3.29 1.50	flexible galvanized
2 1/2" 65	2.875 73.0	1232 85	4.80 122	6.30 160	LEVER	3.85 1.75	flexible galvanized
3" 80	3.500 88.9	1450 100	5.47 139	7.44 189	LEVER	5.25 2.38	flexible painted
3 1/4" 85	3.820 97.0	1450 100	5.75 146	7.72 196	LEVER	6.83 3.10	flexible painted

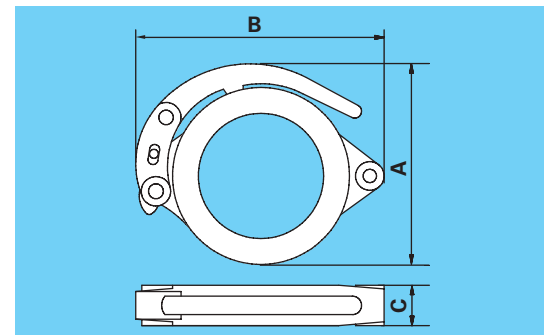

**TES coupling - Ductile Iron**

Nominal size In / DN	Groove size In / mm	Nominal Pressure psi / bar	Approx. Dimensions			Groove	Approx. Weight lbs / Kg
			A in / mm	B in / mm	C in / mm		
2" 50	2.375 60.3	2500 172	3.44 87	6.51 165	1.88 48	TES	3.2 1.5
2 1/2" 65	2.875 73	2500 172	4 102	7.1 180	1.88 48	TES	4.0 1.8
3" 80	3.500 88.9	2500 172	4.69 119	7.74 197	1.88 48	TES	4.6 2.1
4" 100	4.500 114.3	2500 172	5.94 151	9.54 242	2.13 54	TES	8.2 3.7

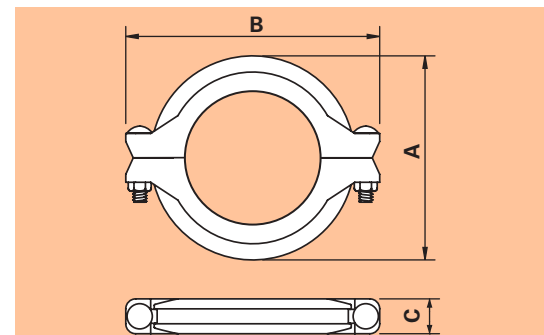

\*\* - US Steel grade is for reference only.

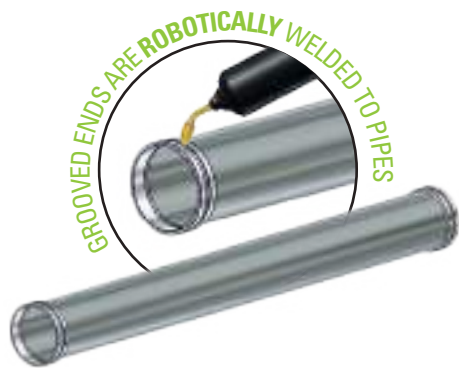

# QUICKLOCK PIPE TYPE C - SNOW

WATER APPLICATION - SNOW MAKING BUSINESS.

- Trasporto d'acqua – Utilizzo nei sistemi d'innevamento artificiale.
- Wasser, Kunstschnee - Erzeugung.
- Transport d'eau pour les activités de neige artificielle.
- Aplicación de agua - Utilizar en los sistemas de fabricación de nieve.

## Pipes Type C - Standard cut grooved dimensions

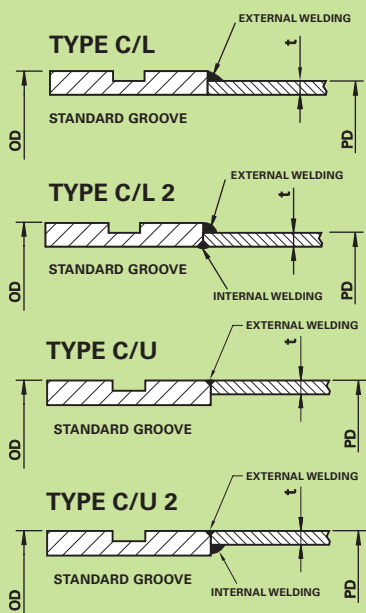

Nominal size In / DN	O.D. inches mm	P.D. inches mm	Nominal Pressure psi / bar	t inches mm	Steel grade US ** EU	Grooved ends type	Black pipe approx. weight 6 m lbs / Kg *
						Groove	
2" / 50	2.375 / 60.3	2.375 / 60.3	580 / 40	0.060 / 1.5	Grade B / S235	C/U standard	29.8 / 13.5
2 1/2" / 65	3.000 / 76.1	70	580 / 40	0.060 / 1.5	Grade B / S235	C/L standard	35.1 / 15.9
3" / 80	3.500 / 88.9	80	580 / 40	0.060 / 1.5	Grade B / S235	C/L2 standard	39.9 / 18.1
4" ✓ / 100	4.500 / 114.3	4.250 / 108	580 / 40	0.080 / 2	Grade B / S235	C/L2 standard	71 / 32.2
5" / 125	5.500 / 139.7	130	580 / 40	0.080 / 2	Grade B / S235	C/L2 standard	86.4 / 39.2
5" / 125	5.563 / 141.3	130	580 / 40	0.080 / 2	Grade B / S235	C/L2 standard	87.3 / 39.6
6" ✓ / 150	6.625 / 168.3	6.250 / 159	580 / 40	0.100 / 2.5	Grade B / S235	C/L2 standard	131 / 59.4
8" / 200	8.625 / 219.1	8.000 / 203	580 / 40	0.119 / 3	X52 / S355	C/L2 standard	203.3 / 92.2
8" / 200	8.625 / 219.1	8.625 / 219.1	580 / 40	0.119 / 3	X52 / S355	C/U2 standard	217 / 98.4

## Pipes Type C - Standard Cut grooved dimensions

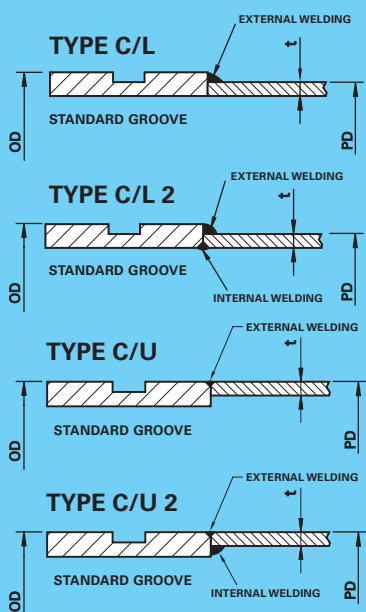

Nominal size In / DN	O.D. inches mm	P.D. inches mm	Nominal Pressure psi / bar	t inches mm	Steel grade US ** EU	Grooved ends type	Black pipe approx. weight 6 m lbs / Kg *
						groove	
2" / 50	2.375 / 60.3	500 / 60.3	1162 / 80	0.080 / 2	Grade B / S235	C/U standard	38.8 / 17.6
2 1/2" / 65	3.000 / 76.1	70	1162 / 80	0.080 / 2	X52 / S355	C/L standard	45.7 / 20.7
3" / 80	3.500 / 88.9	80	1162 / 80	0.080 / 2	X52 / S355	C/L2 standard	52.3 / 23.7
4" / 100	4.500 / 114.3	4.250 / 108	1000 / 69	0.080 / 2	X52 / S355	C/L2 standard	71 / 32.2
4" / 100	4.500 / 114.3	4.250 / 108	1162 / 80	0.119 / 3	X52 / S355	C/L2 standard	104.3 / 47.3
5" / 125	5.500 / 139.7	130	1162 / 80	0.119 / 3	X52 / S355	C/L2 standard	126.8 / 57.5
5" / 125	5.563 / 141.3	130	1162 / 80	0.119 / 3	X52 / S355	C/L2 standard	127.7 / 57.9
6" / 150	6.625 / 168.3	6.250 / 159	1000 / 69	0.119 / 3	X52 / S355	C/L2 standard	155.9 / 70.7
6" / 150	6.625 / 168.3	6.250 / 159	1162 / 80	0.126 / 3.2	X52 / S355	C/L2 standard	165.6 / 75.11
8" / 200	8.625 / 219.1	8.625 / 219.1	800 / 55	0.142 / 3.6	X52 / S355	C/U2 standard	258 / 117
10" / 250	10.750 / 273.0	10.750 / 273	800 / 55	0.156 / 4	X52 / S355	C/U2 standard	360.5 / 163.5
12" / 300	12.750 / 323.9	12.750 / 323.9	800 / 55	0.196 / 5	X52 / S355	C/U2 standard	529.1 / 240

✓ - Most Popular.

\* - Hot dip galvanized pipe weight +10%.

**TECHNICAL NOTES:**

Pipes are bundled in hexagonal rigid bundles to ease unloading, handling and safety at jobsite.  
 Pipes can be manufactured with any thickness available on the market, options indicated are the lower to guarantee pressure rated in application with couplings proposed.  
 Standard lengths are 6 m / 19 ft 8,2 in for truck and 5,85 m / 19 ft 2,3 in for container.  
 Whenever pipes are placed in trench it is imperative making hydraulic test before covering with earth..

**PIPE SURFACE TREATMENT OPTIONS:**

- 1) Black, untreated. Suitable for temporary pipeline.
- 2) Hot dip galvanized EN1461:2009 lead free. Suitable for a long lasting protection from corrosion.
- 3) External anticorrosion coating: layer polyethylene, layer polypropylene, fusion bonded epoxy, dual layer fusion bonded epoxy.  
 Internal coating: liquid paint, flow coat. These external and internal coatings are available only in case of large projects.



**STANDARD Couplings - Ductile Iron**

Nominal size In / DN	Groove size In / mm	Nominal Pressure psi / bar	Approx. Dimensions			Groove	Approx. Weight lbs / Kg
			A in / mm	B in / mm	C in / mm		
2" 50	2.375 60.3	580 40	3.27 83	4.92 125	1.74 44	standard	1.7 0.8
2 1/2" 65	3.000 76.1	580 40	3.94 100	5.71 145	1.78 45	standard	1.9 0.9
3" 80	3.500 88.9	580 40	4.53 115	6.30 160	1.78 45	standard	2.9 1.3
4" 100	4.500 114.3	580 40	5.80 147	8.03 204	2.13 54	standard	4.1 1.9
5" 125	5.500 139.7	580 40	6.80 173	9.59 244	2.13 54	standard	6.3 2.9
5" 125	5.563 141.3	580 40	6.88 175	10.07 256	2.13 54	standard	5.8 2.6
6" 150	6.625 168.3	580 40	8.00 203	11.07 281	2.28 58	standard	7 3.2
8" 200	8.625 219.1	580 40	10.34 263	13.97 355	2.32 59	standard	12.4 5.6
8" 200	8.625 219.1	580 40	10.34 263	13.97 355	2.32 59	standard	12.4 5.6

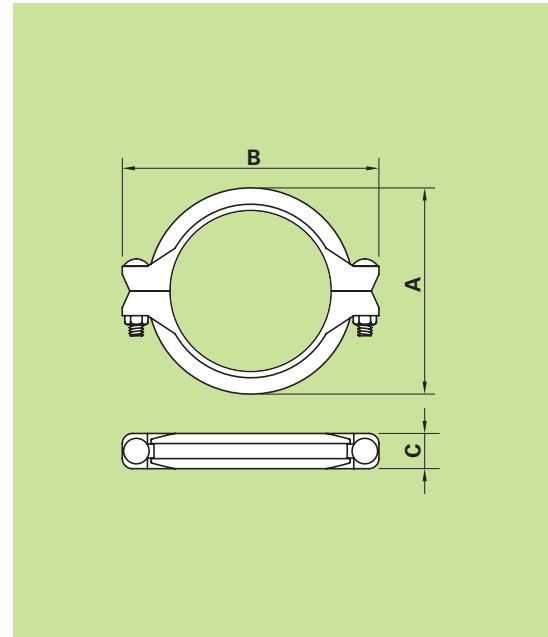

**HP couplings - Ductile Iron**

Nominal size In / DN	Groove size In / mm	Nominal Pressure psi / bar	Approx. Dimensions			Groove	Approx. Weight lbs / Kg
			A in / mm	B in / mm	C in / mm		
2" 50	2.375 60.3	1162 80	3.63 92	5.88 149	1.88 48	standard	2.6 1.2
2 1/2" 65	3.000 76.1	1162 80	4.38 111	6.63 168	1.88 48	standard	3.2 1.5
3" 80	3.500 88.9	1162 80	5.00 127	7.13 181	1.88 48	standard	3.7 1.7
4" 100	4.500 114.3	1000 69	6.13 156	8.88 226	2.13 54	standard	6.7 3
4" 100	4.500 114.3	1162 80	6.13 156	8.88 226	2.13 54	standard	6.7 3
5" 125	5.500 139.7	1162 80	8.63 219	10.65 270	2.13 54	standard	10 4.5
5" 125	5.563 141.3	1162 80	7.75 197	10.65 270	2.13 54	standard	10.6 4.8
6" 150	6.625 168.3	1000 69	8.63 219	11.88 302	2.13 54	standard	12 5.4
6" 150	6.625 168.3	1162 80	8.63 219	11.88 302	2.13 54	standard	12 5.4
8" 200	8.625 219.1	800 55	11.00 279	14.75 375	2.50 63	standard	20.8 9.4
10" 250	10.750 273	800 55	13.63 346	17.13 435	2.63 67	standard	31.1 14.1
12" 300	12.750 323.9	800 55	15.63 397	19.25 489	2.63 67	standard	27.8 12.6

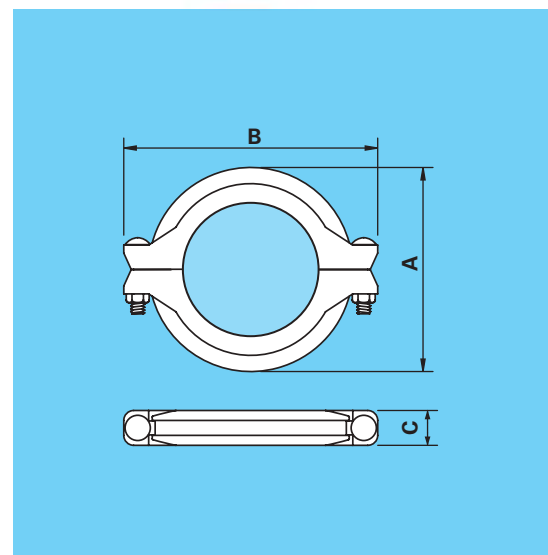

\*\* - US Steel grade is for reference only.



# ROLL GROOVED PIPE

WATER AND AIR APPLICATION - FIRE FIGHTING, INDUSTRIAL, VENTILATION AND AIRCONDITIONING BUSINESS, SHIPBUILDING.

- Trasporto d' acqua e aria - Impianti antincendio, industriali, ventilazione e aria condizionata, costruzioni navali.
- Wasser, Druckluft – Löschwasser, Industriebau, Ventilation- und Klimatechnik, Schiffbau.
- Transport d'eau et d'air – Installation anti-incendie, ventilation, air conditionné, chantiers navals.
- Agua y aplicación de aire - Contra incendio, industrial, ventilación y negocio de aire acondicionado, construcción naval.

## RG Roll Grooved Pipes - Roll grooved dimension

Nominal size In / DN	O.D. inches mm	P.D. inches mm	Nominal Pressure psi / bar	t inches mm	Steel grade US ** EU	Grooved ends type	Black pipe approx. weight 6 m lbs / Kg *	
						Groove		
1" 25	1.315 33.7	1.315 33.7	<b>300</b> <b>21</b>	0.072 1.8	Grade B S235	RG standard	19.4 8.8	
1 1/4" 32	1.660 42.2	1.660 42.2	<b>300</b> <b>21</b>	0.072 1.8	Grade B S235	RG standard	25.4 11.5	
1 1/2" 40	1.900 48.3	1.900 48.3	<b>300</b> <b>21</b>	0.072 1.8	Grade B S235	RG standard	28.7 13	
2" 50	2.375 60.3	2.375 60.3	<b>300</b> <b>21</b>	0.072 1.8	Grade B S235	RG standard	36.4 16.5	
2 1/2" 65	3.000 76.1	3.000 76.1	<b>300</b> <b>21</b>	0.08 2	Grade B S235	RG standard	49.6 22.5	
3" 80	3.500 88.9	3.500 88.9	<b>300</b> <b>21</b>	0.08 2	Grade B S235	RG standard	58.5 26.5	
4" 100 ✓	4.500 114.3	4.500 114.3	<b>300</b> <b>21</b>	0.08 2	Grade B S235	RG standard	75 34	
4" 100 ✓	4.500 114.3	4.500 114.3	<b>400</b> <b>27</b>	0.105 2.6	Grade B S235	RG standard	97 44	
4" 100	4.500 114.3	4.500 114.3	<b>500</b> <b>34</b>	0.119 3	Grade B S235	RG standard	110.7 50.2	
5" 125	5.500 139.7	5.500 139.7	<b>350</b> <b>24</b>	0.109 2.8	Grade B S235	RG standard	127.9 58	
5" 125	5.500 139.7	5.500 139.7	<b>500</b> <b>34</b>	0.142 3.6	Grade B S235	RG standard	162 73.5	
6" 150 ✓	6.625 168.3	6.625 168.3	<b>170</b> <b>12</b>	0.100 2.5	Grade B S235	RG standard	137.8 62.5	
6" 150 ✓	6.625 168.3	6.625 168.3	<b>350</b> <b>24</b>	0.119 3	Grade B S235	RG standard	164.3 74.5	
6" 150	6.625 168.3	6.625 168.3	<b>450</b> <b>31</b>	0.142 3.6	Grade B S235	RG standard	196.3 89	
8" 200	8.625 219.1	8.625 219.1	<b>225</b> <b>16</b>	0.119 3	Grade B S235	RG standard	213.9 97	
8" 200 ✓	8.625 219.1	8.625 219.1	<b>300</b> <b>21</b>	0.142 3.6	Grade B S235	RG standard	225.8 116	
10" 250	10.750 273	10.750 273	<b>300</b> <b>21</b>	0.164 4.2	Grade B S235	RG standard	372.6 169	
12" 300	12.750 323.9	12.750 323.9	<b>125</b> <b>9</b>	0.164 4.2	Grade B S235	RG standard	442 200.5	

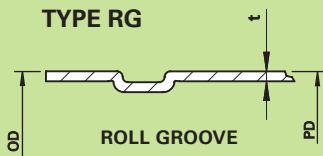

✓ - Most Popular.

\* - Hot dip galvanized pipe weight +10%.

**TECHNICAL NOTES:**

Pipes are bundled in hexagonal rigid bundles to ease unloading, handling and safety at jobsite.  
 Pipes can be manufactured with any thickness available on the market, options indicated are the lower to guarantee pressure rated in application with couplings proposed.  
 Standard lengths are 6 m / 19 ft 8,2 in for truck and 5,85 m / 19 ft 2,3 in for container.  
 Whenever pipes are placed in trench it is imperative making hydraulic test before covering with earth.

**PIPE SURFACE TREATMENT OPTIONS:**

- 1) Black, untreated. Suitable for temporary pipeline.
- 2) Hot dip galvanized EN1461:2009 lead free. Suitable for a long lasting protection from corrosion.
- 3) External light painting with water based liquid coating. Suitable when short terms protection it is acceptable.
- 4) External anticorrosion coating: layer polyethylene, layer polypropylene, fusion bonded epoxy, dual layer fusion bonded epoxy.  
 Internal coating: liquid paint, flow coat. These external and internal coatings are available only in case of large projects.



**STANDARD Couplings - Ductile Iron**

Nominal size In /DN	Groove size In /mm	Nominal Pressure psi/bar	Approx. Dimensions			Groove	Approx. Weight lbs / Kg
			A in / mm	B in / mm	C in / mm		
1" 25	1.315 33.7	500 34	2.38 61	4.27 108	1.77 45	standard	1.3 0.6
1 1/4" 32	1.660 42.2	500 34	2.68 68	4.61 117	1.77 45	standard	1.4 0.6
1 1/2" 40	1.900 48.3	500 34	2.91 74	4.82 122	1.77 45	standard	1.5 0.6
2" 50	2.375 60.3	500 34	3.27 83	4.92 125	1.74 44	standard	1.7 0.8
2 1/2" 65	3.000 76.1	500 34	3.94 100	5.71 145	1.78 45	standard	1.9 0.9
3" 80	3.500 88.9	500 34	4.53 115	6.30 160	1.78 45	standard	2.9 1.3
4" 100	4.500 114.3	500 34	5.80 147	8.03 204	2.13 54	standard	4.1 1.9
4" 100	4.500 114.3	500 34	5.80 147	8.03 204	2.13 54	standard	4.1 1.9
4" 100	4.500 114.3	500 34	5.80 147	8.03 204	2.13 54	standard	4.1 1.9
5" 125	5.500 139.7	450 31	6.80 173	9.59 244	2.13 54	standard	6.3 2.9
5" 125	5.500 139.7	450 31	6.80 173	9.59 244	2.13 54	standard	6.3 2.9
6" 150	6.625 168.3	450 31	8.00 203	11.07 281	2.28 58	standard	7 3.2
6" 150	6.625 168.3	450 31	8.00 203	11.07 281	2.28 58	standard	7 3.2
6" 150	6.625 168.3	450 31	8.00 203	11.07 281	2.28 58	standard	7 3.2
8" 200	8.625 219.1	450 31	10.34 263	13.97 355	2.32 59	standard	12.4 5.6
8" 200	8.625 219.1	450 31	10.34 263	13.97 355	2.32 59	standard	12.4 5.6
10" 250	10.750 273	300 21	13.27 337	16.00 406	2.56 65	standard	24.0 10.9
12" 300	12.750 323.9	300 21	14.96 378	18.31 465	2.56 65	standard	27.8 12.6

\*\* - US Steel grade is for reference only.

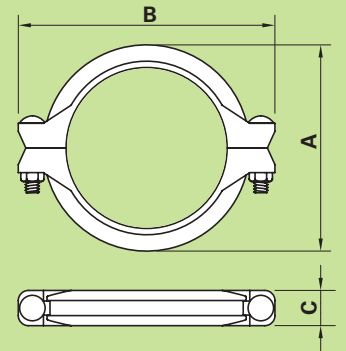

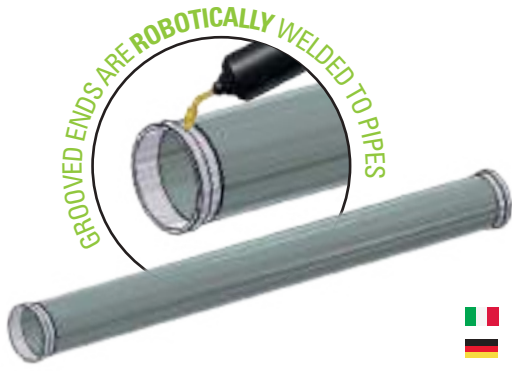

# QUICKLOCK PIPE TYPE D - SWE QUICKLOCK PIPE TYPE B - AUS

WATER AND AIR APPLICATION - TUNNELING, MINING, INDUSTRIAL BUSINESS.

- Trasporto acqua e aria - Utilizzo in galleria, industria mineraria, attività industriali.
- Wasser, Druckluft – Tunnelbau, Bergbau, Industriebau.
- Transport d'eau et d'air – Tunnel, industrie minière, industries diverses.
- Agua y aplicación de aire - Construcción de un túnel, minería, negocio industrial.

## Pipe Type D Sweden

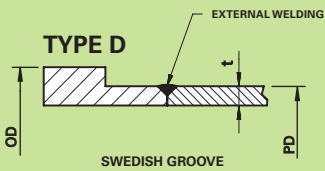

Nominal size Inches	O.D. mm	PD. mm	Nominal Pressure psi/bar	t mm	Steel grade EU	Grooved ends type Groove
1 1/2"	52	48	40	2	S235	swedish
2"	64	60	40	1.8	S235	swedish
2 1/2"	83	76	40	2	S235	swedish
4" ✓	108	101.6	40	2	S235	swedish
6" ✓	161	152.4	40	2.1	S355	swedish
6"	161	152.4	40	2.5	S235	swedish
8"	217	203	16	3	S235	swedish

## Pipe Type B Australia

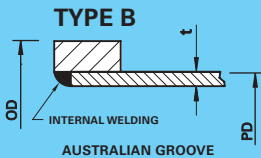

Nominal size Inches DN	O.D. mm	PD. mm	Nominal Pressure psi/bar	t mm	Steel grade EU	Grooved ends type Groove
100	122	114.3	34	1.5	S235	australian
100	122	114.3	34	2	S235	australian
150	174.5	168.3	21	1.5	S235	australian
150	174.5	165.1	31	2.5	S235	australian

✓ - Most Popular. \* - Hot dip galvanized pipe weight +10%.

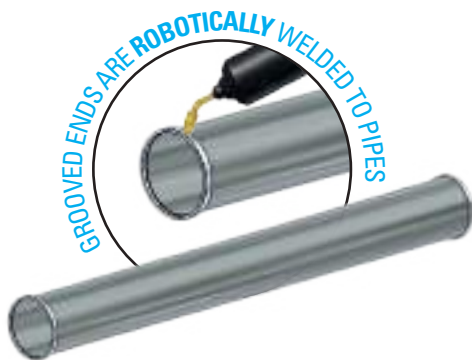

### TECHNICAL NOTES:





Pipes can be manufactured with any thickness available on the market, options indicated are the lower to guarantee pressure rated in application with couplings proposed.  
Standard lengths are 6 m / 19 ft 8,2 in for truck and 5,85 m / 19 ft 2,3 in for container.

### PIPE SURFACE TREATMENT OPTIONS:

- 1) Black, untreated. Suitable for temporary pipeline.
- 2) Hot dip galvanized EN1461:2009 lead free. Suitable for a long lasting protection from corrosion.
- 3) External light painting with water based liquid coating. Suitable when short terms protection it is acceptable.
- 4) External anticorrosion coating: layer polyethylene, layer polypropylene, fusion bonded epoxy, dual layer fusion bonded epoxy.  
Internal coating: liquid paint, flow coat. These external and internal coatings are available only in case of large projects.

# THREADED PIPE

WATER AND GAS APPLICATION - INDUSTRIAL AND CIVIL ENGINEERING BUSINESS.

-  Trasporto d' acqua e gas - Impianto di costruzione civile e industriale.
-  Wasser, Gas – Bauwesen, Industriebau.
-  Transport d'eau et de gaz – Équipement du BTP, industrie.
-  Aplicación de agua y gas - Empresas industriales y de ingeniería civil.

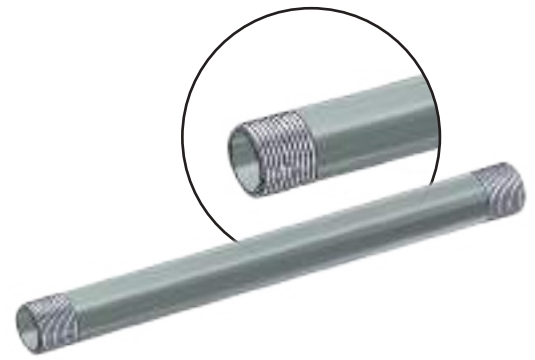

## Threaded pipe **Welded - Welded steel pipe: ASTM A53/95 EN10217**

Nominal size Inches DN	O.D. inches mm	Light series EN10255		Medium series EN10255		Hard series EN10255	
		N. Pressure psi/bar	t inch/mm	N. Pressure psi/bar	t inch/mm	N. Pressure psi/bar	t inch/mm
1" 25	1.315 33.7	145 10	0.115 2.9	225 16	0.125 3.2	225 16	0.156 4
1 1/4" 32	1.660 42.4	145 10	0.115 2.9	225 16	0.125 3.2	225 16	0.156 4
1 1/2" 40	1.900 48.3	145 10	0.115 2.9	225 16	0.125 3.2	225 16	0.156 4
2" 50	2.375 60.3	145 10	0.125 3.2	225 16	0.142 3.6	225 16	0.196 4.5
2 1/2" 65	3.000 76.1	145 10	0.125 3.2	225 16	0.142 3.6	225 16	0.196 4.5
3" 80	3.500 88.9	145 10	0.142 3.6	225 16	0.156 4	225 16	0.196 5
4" 100	4.500 114.3	145 10	0.156 4	225 16	0.196 4.5	225 16	0.211 5.4
5" 125	5.500 139.7	-	-	225 16	0.196 5	225 16	0.211 5.4
6" 150	6.500 165.1	-	-	225 16	0.196 5	225 16	0.211 5.4

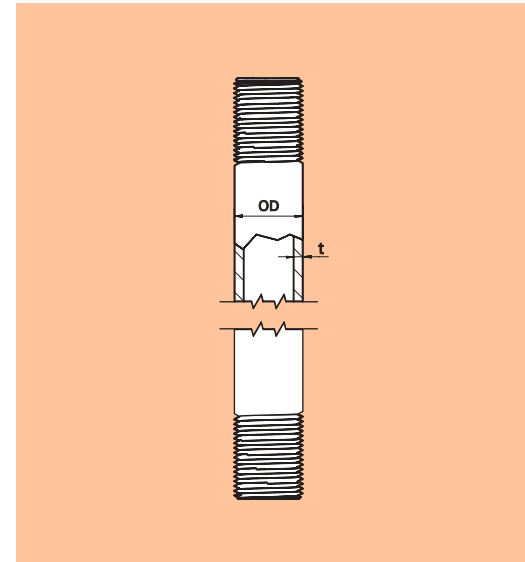

## Threaded pipe **Seamless - Seamless steel pipe: ASTM A53/95 EN10216**

Nominal size Inches DN	O.D. inches mm	Light series EN10255		Medium series EN10255		Hard series EN10255	
		N. Pressure psi/bar	t inch/mm	N. Pressure psi/bar	t inch/mm	N. Pressure psi/bar	t inch/mm
1" 25	1.315 33.7	145 10	0.115 2.9	225 16	0.125 3.2	225 16	0.156 4
1 1/4" 32	1.660 42.4	145 10	0.115 2.9	225 16	0.125 3.2	225 16	0.156 4
1 1/2" 40	1.900 48.3	145 10	0.115 2.9	225 16	0.125 3.2	225 16	0.156 4
2" 50	2.375 60.3	145 10	0.125 3.2	225 16	0.142 3.6	225 16	0.196 4.5
2 1/2" 65	3.000 76.1	145 10	0.125 3.2	225 16	0.142 3.6	225 16	0.196 4.5
3" 80	3.500 88.9	145 10	0.142 3.6	225 16	0.156 4	225 16	0.196 5
4" 100	4.500 114.3	145 10	0.156 4	225 16	0.196 4.5	225 16	0.211 5.4
5" 125	5.500 139.7	-	-	225 16	0.196 5	225 16	0.211 5.4
6" 150	6.500 165.1	-	-	225 16	0.196 5	225 16	0.211 5.4

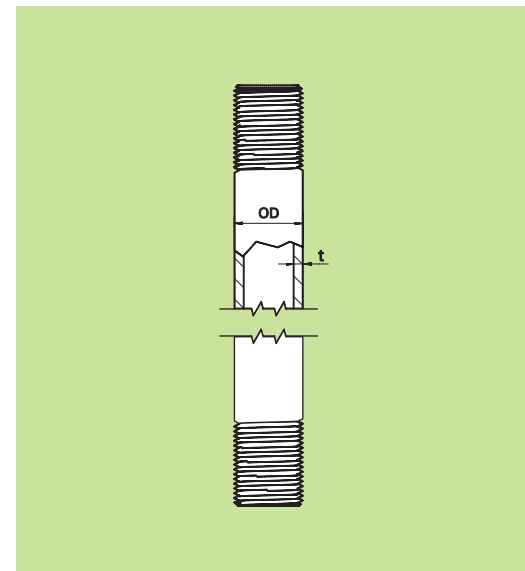

\*\* - US Steel grade is for reference only.

### TECHNICAL NOTES:

Threaded : ISO7/1, BS21, ANSI/ASME B1.20.1.  
 Each pipe is supplied with a socket UNI ISO 50.  
 Pipes are tested 5 seconds at 50 bar.  
 Standard lengths are 6 m / 19 ft 8.2 in for truck and 5.85 m / 19 ft 2.3 in for container.

### PIPE SURFACE TREATMENT OPTIONS:

Black or Galvanized following EN10240/ASTM A53, lead free.



# SPHERICAL PIPE

LOW PRESSURE WATER APPLICATION - TUNNELING, MINING, AGRICULTURE, IRRIGATION AND CIVIL ENGINEERING BUSINESS.



Trasporto d'acqua in bassa pressione - Utilizzo in galleria, irrigazione, agricoltura, industria mineraria, ingegneria civile.



Niederdruck- Wasser – Tunnelbau, Bergbau, Landwirtschaft, Bewässerung, Bauwesen.



Transport d'eau basse pression – Tunnel, irrigation, mines, BTP.



Aplicación de agua a baja presión - Túneles, minería, agricultura, riego y obras de ingeniería civil.

## Steel pipe with ITA joint

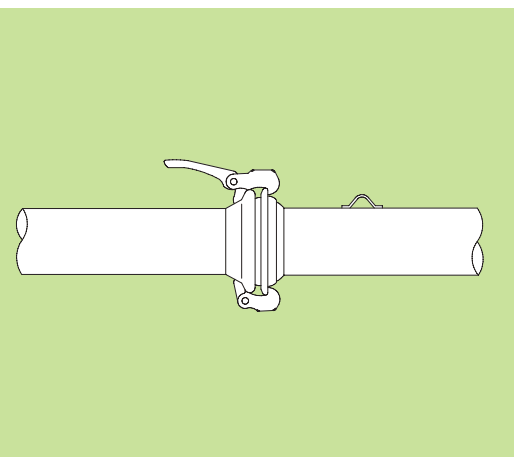

D. mm	PN		t		Steel grade EU	Ends type
	bar	PSI	mm	inches		
50	15	217	1.5	0.060	S235	ita
60	10	145	1	0.039	DC01	ita
60	10	145	1.5	0.060	S235	ita
80	9	130	1	0.039	DC01	ita
80	9	130	1.5	0.060	S235	ita
100	8	116	1	0.039	DC01	ita
100	8	116	2	0.080	S235	ita
120	7	101	1	0.039	DC01	ita
150	6	87	1.2	0.047	DC01	ita
150	15	217	2	0.080	S235	ita
200	8	116	2	0.080	S235	ita
250	6	87	2	0.080	S235	ita
300	6	87	2	0.080	S235	ita

## Steel pipe with BA joint

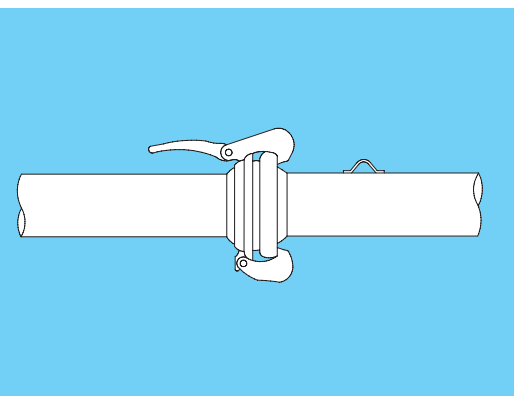

D. mm	PN		t		Steel grade EU	Ends type
	bar	PSI	mm	inches		
50	20	290	1.5	0.060	S235	ba
76	20	290	1.5	0.060	S235	ba
89	20	290	1.5	0.060	S235	ba
108	15	217	1.5	0.060	S235	ba
133	12	174	1.5	0.060	S235	ba
159	12	174	1.5	0.060	S235	ba
194	12	174	2	0.080	S235	ba
250	12	174	2.5	0.100	S235	ba
300	12	174	2.5	0.100	S235	ba
400	6	87	5	0.196	S235	ba
450	6	87	5	0.196	S235	ba

## Steel pipe with CA joint

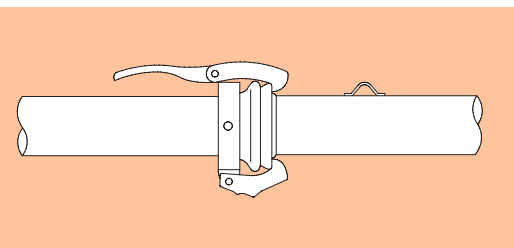

D. mm	PN		t		Steel grade EU	Ends type
	bar	PSI	mm	inches		
50	20	290	1.5	0.060	S235	ca
70	20	290	1.5	0.060	S235	ca
89	15	217	1.5	0.060	S235	ca
108	15	217	1.5	0.060	S235	ca
133	13	188	1.5	0.060	S235	ca
159	10	145	1.5	0.060	S235	ca

### TECHNICAL NOTES:

Pipes can be manufactured with any thickness available on the market, options indicated are the lower to guarantee pressure rated in application with couplings proposed.

Standard lengths are 6 m / 19 ft 8,2 in for truck.

### PIPE SURFACE TREATMENT OPTIONS:

1) Black, untreated. Suitable for temporary pipeline.

2) Hot dip galvanized EN1461:2009 lead free. Suitable for a long lasting protection from corrosion.

3) External light painting with water based liquid coating. Suitable when short terms protection it is acceptable.

## QUICKLOCK GROOVED END TO BE WELDED TYPE C

### STEEL - TL80

Diameters from 2" to 20"

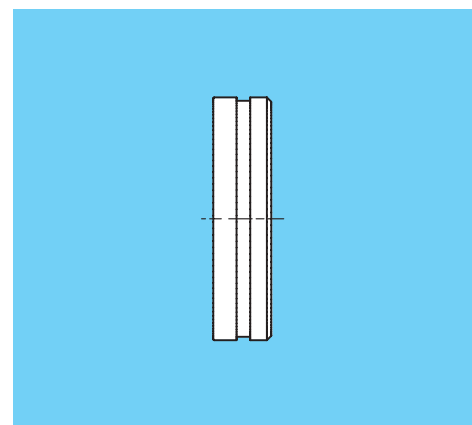

## QUICKLOCK GROOVED END TO BE WELDED TYPE B

### STEEL - TL81

Diameters from 2" to 6"

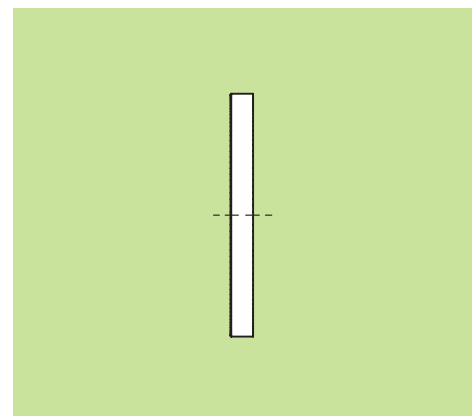

## GASKET, SPARE PART FOR QUICKLOCK COUPLING

### EPDM - TL70

Diameters from 1" to 20"  
See pag 38 for other options

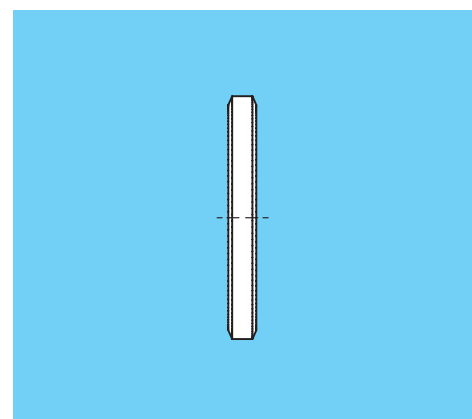

## GASKET, SPARE PART FOR FLANGE

### EPDM OR SESALIT - GUA

Diameters from 2" to 20"

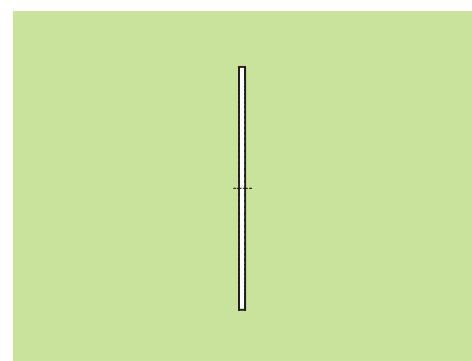

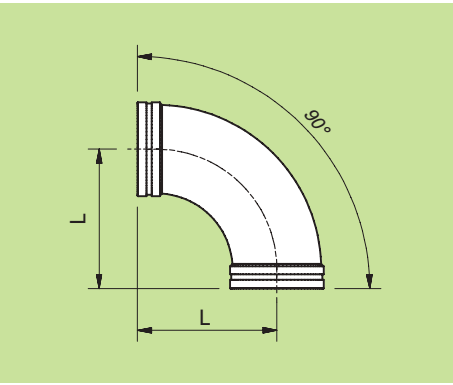

## QUICKLOCK ELBOW 90°

### STEEL

PN21 ÷ PN69  
PSI 300 ÷ PSI 1000

### TL30S

short radius  
DIMA 3 R=1,5D

### TL30L

long radius  
DIMA 5 R=2,5D

### DUCTILE IRON

PN21 ÷ PN34  
PSI 300 ÷ PSI 500

### TL30X

reduced radius

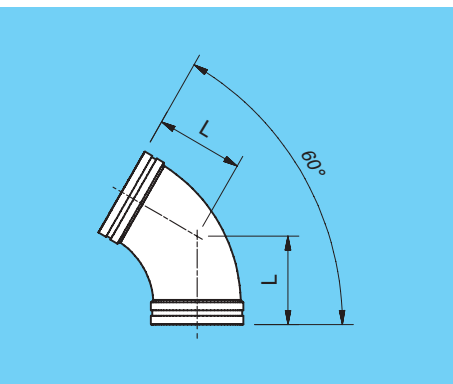

## QUICKLOCK ELBOW 60°

### STEEL

PN21 ÷ PN69  
PSI 300 ÷ PSI 1000

### TL31S

short radius  
DIMA 3 R=1,5D

### TL31L

long radius  
DIMA 5 R=2,5D

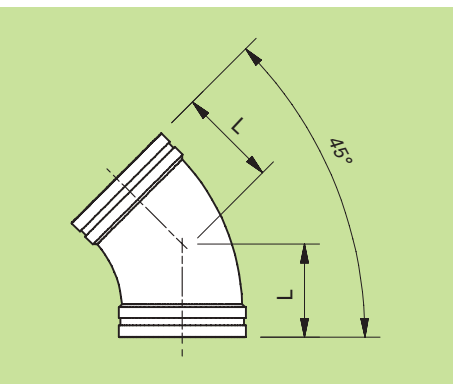

## QUICKLOCK ELBOW 45°

### STEEL

PN21 ÷ PN69  
PSI 300 ÷ PSI 1000

### TL32S

short radius  
DIMA 3 R=1,5D

### TL32L

long radius  
DIMA 5 R=2,5D

### DUCTILE IRON

PN21 ÷ PN34  
PSI 300 ÷ PSI 500

### TL32X

reduced radius

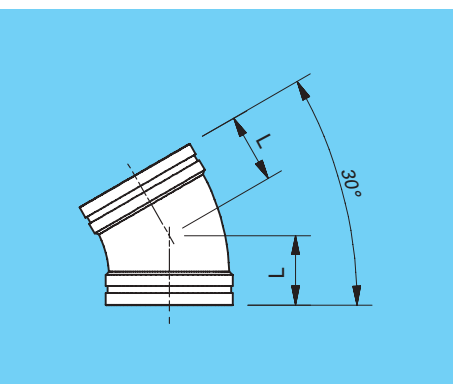

## QUICKLOCK ELBOW 30°

### STEEL

PN21 ÷ PN69  
PSI 300 ÷ PSI 1000

### TL33S

short radius  
DIMA 3 R=1,5D

### TL33L

long radius  
DIMA 5 R=2,5D



## QUICKLOCK ELBOW 15°

### STEEL

PN21 ÷ PN69  
PSI 300 ÷ PSI 1000

### TL34S

short radius  
DIMA 3 R=1,5D

### TL34L

long radius  
DIMA 5 R=2,5D

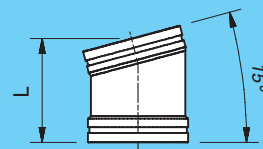

## QUICKLOCK ELBOW 7 1/2°

### STEEL

PN21 ÷ PN69  
PSI 300 ÷ PSI 1000

### TL35S

short radius  
DIMA 3 R=1,5D

### TL35L

long radius  
DIMA 5 R=2,5D

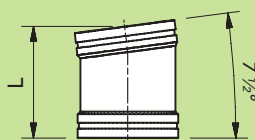

## QUICKLOCK ELBOW 22 1/2°

### DUCTILE IRON

PN21 ÷ PN34  
PSI 300 ÷ PSI 500

### TL38X

reduced radius

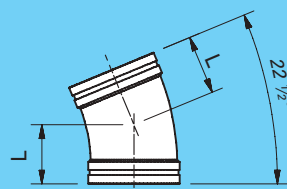

## QUICKLOCK ELBOW 11 1/4°

### DUCTILE IRON

PN21 ÷ PN34  
PSI 300 ÷ PSI 500

### TL39X

reduced radius

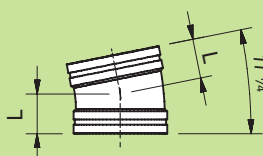

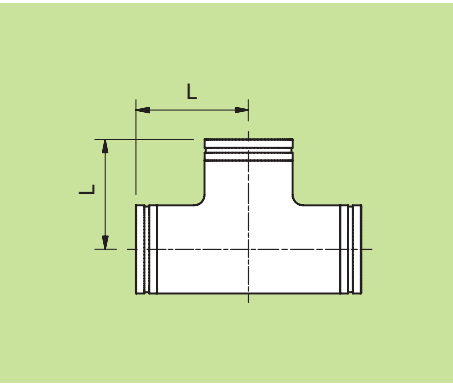

## QUICKLOCK EQUAL TEE

### STEEL

PN21 ÷ PN69  
PSI 300 ÷ PSI 1000

### TL50C

standard dimension

### DUCTILE IRON

PN21 ÷ PN34  
PSI 300 ÷ PSI 500

### TL50X

reduced dimension

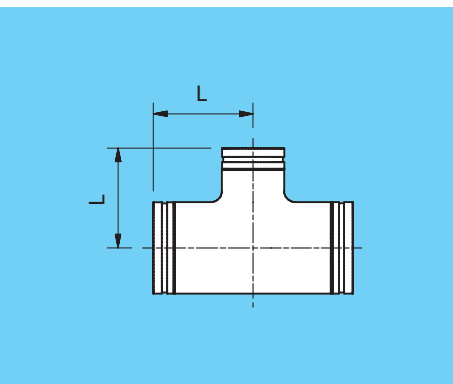

## QUICKLOCK REDUCING TEE

### STEEL

PN21 ÷ PN69  
PSI 300 ÷ PSI 1000

### TL51C

standard dimension

### DUCTILE IRON

PN21 ÷ PN34  
PSI 300 ÷ PSI 500

### TL51X

reduced dimension

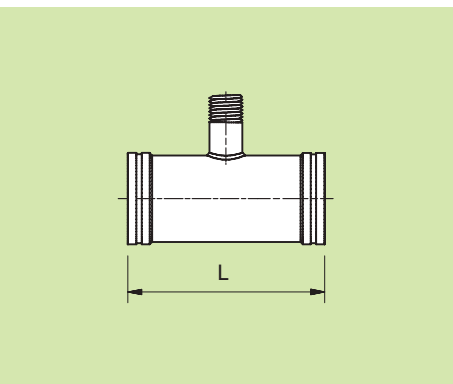

## QUICKLOCK TEE WITH MALE THREADED OUTLET

### STEEL

PN21 ÷ PN34  
PSI 300 ÷ PSI 500

### TL52C

on request state  
outlet diameter

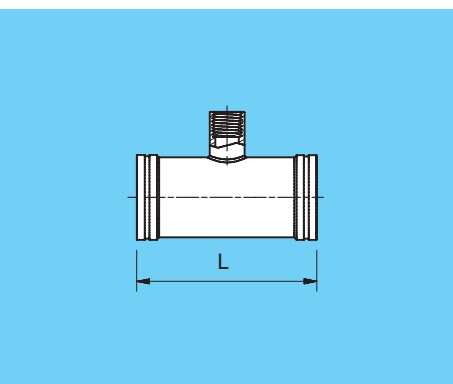

## QUICKLOCK TEE WITH FEMALE THREADED OUTLET

### STEEL

PN21 ÷ PN69  
PSI 300 ÷ PSI 1000

### TL53C

on request state  
outlet diameter



# QUICKLOCK CROSS

## STEEL

PN21 ÷ PN69  
PSI 300 ÷ PSI 1000

## TL59C

standard dimension

## DUCTILE IRON

PN21 ÷ PN34  
PSI 300 ÷ PSI 500

## TL59X

reduced dimension

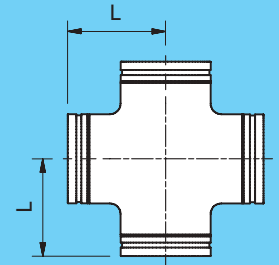

# QUICKLOCK ON LINE DISTRIBUTOR

## STEEL

PN21 ÷ PN69  
PSI 300 ÷ PSI 1000

## TL54C

on request state the following:

- male or female's outlet
- outlet's diameter
- outlet's number

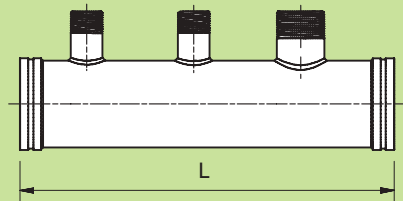

# QUICKLOCK END DISTRIBUTOR

## STEEL

PN21 ÷ PN69  
PSI 300 ÷ PSI 1000

## TL55C

on request state the following:

- male or female's outlet
- outlet's diameter
- outlet's number

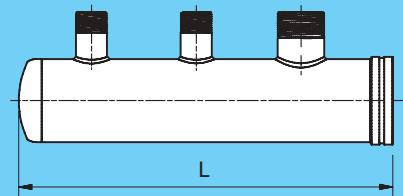

# QUICKLOCK SERVICE DISTRIBUTOR

## STEEL

PN21 ÷ PN69  
PSI 300 ÷ PSI 1000

## TL56C

on request state the following:

- male or female's outlet
- outlet's diameter
- outlet's number

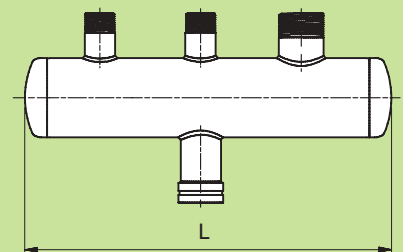

## QUICKLOCK CONCENTRIC REDUCER

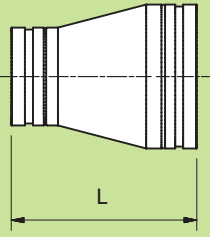

### STEEL

PN21 ÷ PN69  
PSI 300 ÷ PSI 1000

### TL41C

standard dimension

### DUCTILE IRON

PN21 ÷ PN34  
PSI 300 ÷ PSI 500

### TL41X

reduced dimension



## QUICKLOCK ECCENTRIC REDUCER

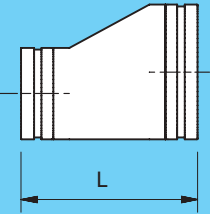

### STEEL

PN21 ÷ PN69  
PSI 300 ÷ PSI 1000

### TL48C

standard dimension



## QUICKLOCK CONCENTRIC REDUCER WITH MALE SOCKET

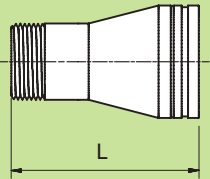

### STEEL

PN21 ÷ PN34  
PSI 300 ÷ PSI 500

### TL49C

on request state  
outlet diameter



## QUICKLOCK CONCENTRIC REDUCER WITH FEMALE SOCKET

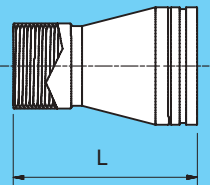

### STEEL

PN21 ÷ PN69  
PSI 300 ÷ PSI 1000

### TL45C

on request state  
outlet diameter



## AXIAL COMPENSATOR

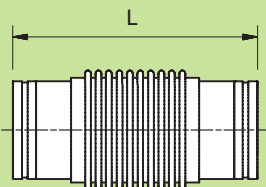

### STEEL

PN10 ÷ PN16  
PSI 145 ÷ PSI 225

### QV

standard dimension



## QUICKLOCK CAP

### STEEL

PN21 ÷ PN69  
PSI 300 ÷ PSI 1000

### TL40C

standard dimension

### DUCTILE IRON

PN21 ÷ PN34  
PSI 300 ÷ PSI 500

### TL40X

standard dimension

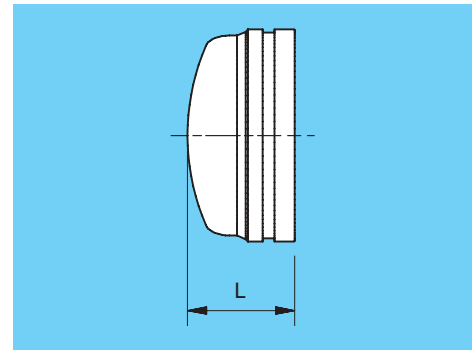

## QUICKLOCK CAP WITH MALE SOCKET

### STEEL

PN21 ÷ PN34  
PSI 300 ÷ PSI 500

### TL42C

on request state  
outlet diameter

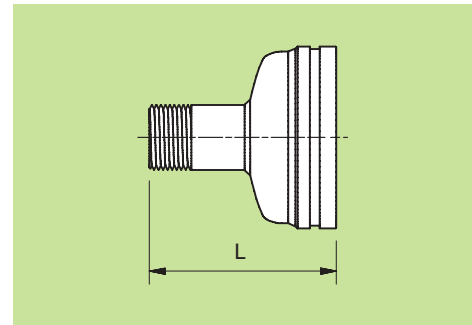

## QUICKLOCK CAP WITH FEMALE SOCKET

### STEEL

PN21 ÷ PN69  
PSI 300 ÷ PSI 1000

### TL43C

on request state  
outlet diameter

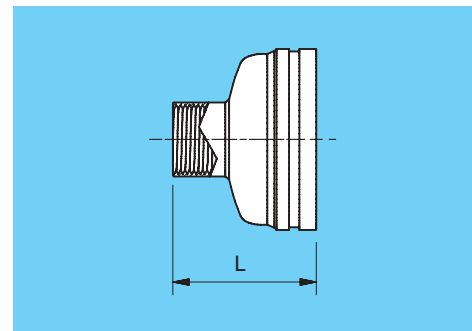

## QUICKLOCK MALE SOCKET

### STEEL

PN21 ÷ PN34  
PSI 300 ÷ PSI 500

### TL46C

on request state  
outlet diameter

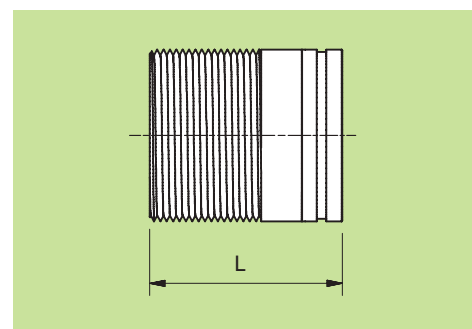

## QUICKLOCK FEMALE SOCKET

### STEEL

PN21 ÷ PN69  
PSI 300 ÷ PSI 1000

### TL47C

on request state  
outlet diameter

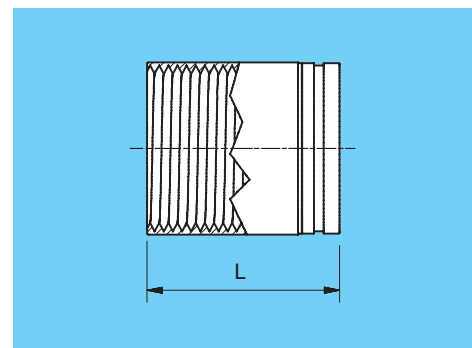

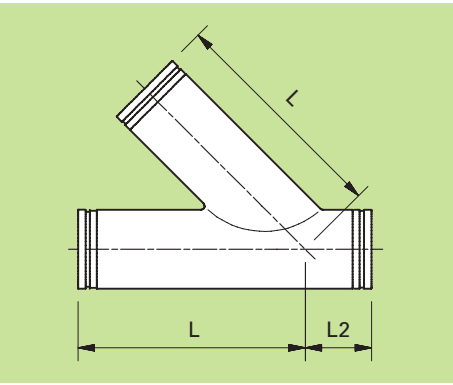

## 45° LATERAL QUICKLOCK TEE

### STEEL

PN21 ÷ PN69  
PSI 300 ÷ PSI 1000

### TL61C

standard dimension

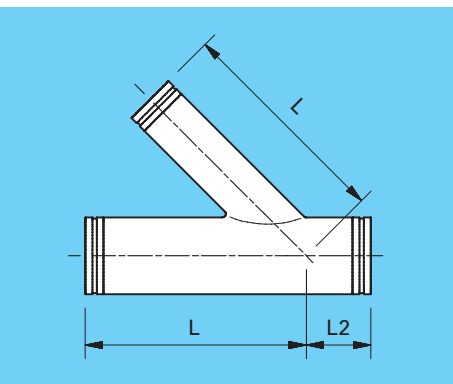

## 45° REDUCING LATERAL QUICKLOCK TEE

### STEEL

PN21 ÷ PN69  
PSI 300 ÷ PSI 1000

### TL62C

standard dimension

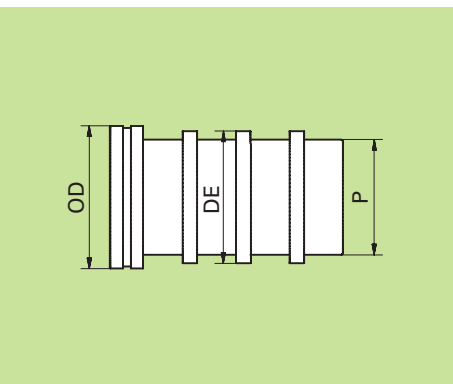

## QUICKLOCK HOSE SPIGOT MACHINED PIPE

### STEEL

PN21 ÷ PN69  
PSI 300 ÷ PSI 1000

### TL44C

on request state  
outlet diameter

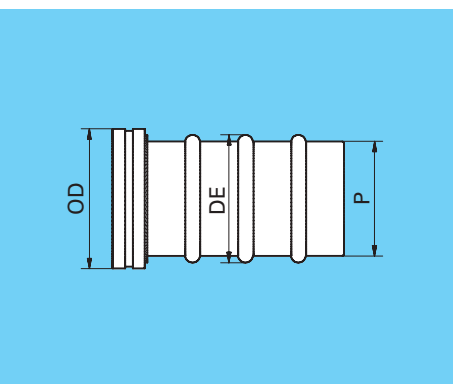

## QUICKLOCK HOSE SPIGOT ROLLED PIPE

### STEEL

PN21 ÷ PN69  
PSI 300 ÷ PSI 1000

### TL44R

on request state  
outlet diameter



# QUICKLOCK FLANGED OUTLET

## STEEL

PN6 ÷ PN64  
PSI 87 ÷ PSI 928

## TL60C

on request state the following:

- flange EN/UNI PN6 ÷ PN64 ASA 150/300/600
- DIN standard
- type of flanges, flat, welding neck, slip on, ring joint

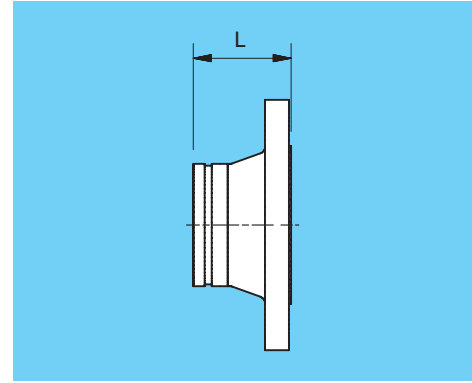

## DUCTILE IRON

PN16  
PSI 225

## TL60X

standard dimension

# GROOVED FLANGE ADAPTER

## DUCTILE IRON

PN16  
PSI 225

## 321

standard dimension

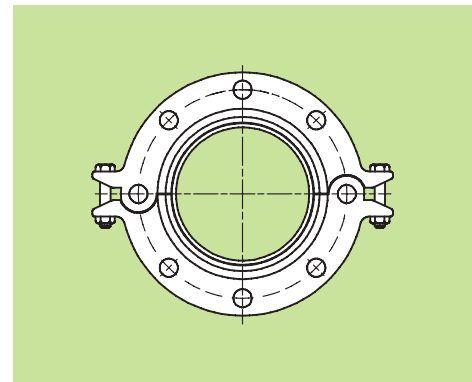

# FLANGED RUBBER BELLOWS

## STEEL RUBBER

PN10 ÷ PN16  
PSI 145 ÷ PSI 225

## FSF

on request state the following:

- flange type and standard
- bellow's material
- bellow's expansion

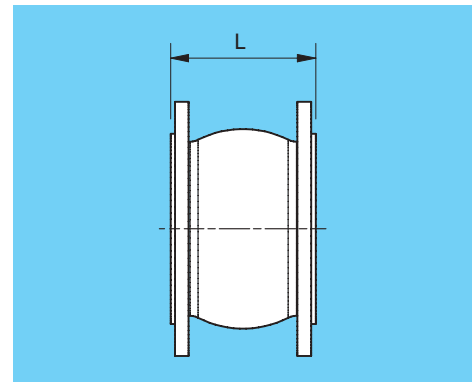

# LUBRICANT FOR COUPLINGS

## TL260001

900gr = 1 can

indication on the number of gasket which can be lubricated with 1 can:

- |                |                |
|----------------|----------------|
| • 2" - 440 pcs | • 10" - 80 pcs |
| • 3" - 300 pcs | • 12" - 60 pcs |
| • 4" - 220 pcs | • 14" - 50 pcs |
| • 6" - 135 pcs | • 16" - 50 pcs |
| • 8" - 110 pcs | • 20" - 30 pcs |



# BUTTERFLY VALVE

## WAFER DUCTILE IRON VFW / L

Pressure  
PN 16 - PSI 232  
PN 25 - PSI 360

Diameters  
1½" ÷ 12"  
1½" ÷ 6"



## WAFER WITH GEAR BOX DUCTILE IRON VFW / G

Pressure  
PN 10 - PSI 145  
PN 16 - PSI 232  
PN 25 - PSI 360

Diameters  
6" ÷ 20"  
6" ÷ 20"  
6" ÷ 20"



## QUICKLOCK DUCTILE IRON 39101

Pressure  
PN 16 - PSI 232  
PN 21 - PSI 300  
PN 25 - PSI 360

Diameters  
1½" ÷ 12"  
1½" ÷ 12"



# CHECK VALVE

## DOUBLE DOOR DUCTILE IRON VRIT

Pressure  
PN 16 - PSI 232

Diameters  
2" ÷ 16"



## FLANGED SWING DUCTILE IRON VNRC

Pressure  
PN 10 - PSI 145  
PN 16 - PSI 232  
PN 25 - PSI 360  
PN 40 - PSI 580  
PN 63 - PSI 910

Diameters  
2" ÷ 12"  
2" ÷ 12"  
2" ÷ 20"  
2" ÷ 20"  
2" ÷ 20"  
2" ÷ 12"



## QUICKLOCK SWING DUCTILE IRON VNRCQ

Pressure  
PN 16 - PSI 232  
PN 21 - PSI 300  
PN 25 - PSI 360

Diameters  
2" ÷ 12"  
1½" ÷ 12"



# BALL VALVE

## THREADED BRASS VSO / L

Pressure  
PN 40 - PSI 580  
on request full bore

Diameters  
½" ÷ 4"



## THREADED - HIGH PRESSURE BRASS VSO / H

Pressure  
PN100 - PSI 1450  
PN80 - PSI 1160  
on request full bore

Diameters  
½" ÷ 1½"  
½" ÷ 2"



## QUICKLOCK STEEL VSO / Q

Pressure  
PN55 - PSI 800

Diameters  
1½" ÷ 6"



# GATE VALVE

## QUICKLOCK DUCTILE IRON

VSQ

Pressure  
PN 10 - PSI 145  
PN 16 - PSI 232

Diameters  
2" ÷ 12"  
2" ÷ 6"



## FLANGED DUCTILE IRON

VSA / L

Pressure  
PN 10 - PSI 145  
PN 16 - PSI 232  
PN 25 - PSI 360

Diameters  
2" ÷ 20"  
2" ÷ 20"  
2" ÷ 20"



## FLANGED - HIGH PRESSURE STEEL

VSA / H

Pressure  
PN 40 - PSI 580  
PN 63 - PSI 910  
PN 100 - PSI 1450

Diameters  
2" ÷ 20"  
2" ÷ 12"  
2" ÷ 12"



# KNIFE GATE VALVE

## HAND WHEEL KNIFE GATE DUCTILE IRON

VKG / H

Pressure  
PN 10 - PSI 145  
PN 16 - PSI 232

Diameters  
2" ÷ 20"  
2" ÷ 20"



## GEAR BOX KNIFE GATE DUCTILE IRON

VKG / G

Pressure  
PN 10 - PSI 145  
PN 16 - PSI 232

Diameters  
2" ÷ 20"  
2" ÷ 20"



## HYDRAULIC KNIFE GATE DUCTILE IRON

VKG / P

Pressure  
PN 10 - PSI 145  
PN 16 - PSI 232

Diameters  
2" ÷ 20"  
2" ÷ 20"



## HAND LEVER KNIFE GATE DUCTILE IRON

VKG / L

Pressure  
PN 10 - PSI 145  
PN 8 - PSI 116  
PN 6 - PSI 87

Diameters  
2" ÷ 6"  
8"  
10"



## HYDRANT WITH BOX TLG 68 / CAS

Pressure  
PN 16 - PSI 232



## THREADED FEMALE GATE VALVE STEEL

VSF

Pressure  
PN 16 - PSI 232

Diameters  
2" ÷ 4"



# GENERAL: THE QUICKLOCK SYSTEM

Quicklock Grooved Products are designed for use within grooved end pipe systems and are available in nominal sizes from 25 mm (1") to 600 mm (24") depending on the coupling figure number. The Quicklock Coupling design provides several cost advantages over welded or flanged systems. They also provide a universal means for the connection of pipe, fittings and pipe system components.

Quicklock Couplings and Gaskets permit the selection of suitable combinations for specific application. Field modifications are easily accommodated with Quicklock Grooved Couplings as the couplings can be easily rotated, added or taken out, to allow necessary modifications.

\*Flexible Couplings act as an "expansion joint", allowing linear and angular movement of the pipe. They are designed so the coupling keys engage the pipe without gripping on the bottom of the grooves, yet still providing a restrained mechanical joint. This is particularly useful to allow for pipe expansion or contraction and piping misalignment.

\*Rigid Couplings provide rigid gripping of the pipe. They are designed to bring the pipe ends closely together and the coupling clamps firmly onto the pipe OD and also onto the bottom of the grooves. Because Rigid Couplings clamp around the entire pipe surface, they provide resistance to flexural loads and therefore permit longer spacing to ASME/ANSI B31.1 (Power Piping) and ASME/ANSI B39.1 (Building Services) requirements as well as NFPA 13 (Sprinkler Systems).

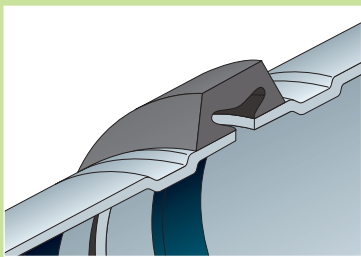

**First seal**  
C-shape rubber gasket naturally seals on pipe ends.

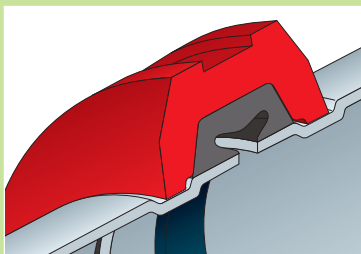

**Second seal**  
The housings compress the gasket to increase the sealing capacity.

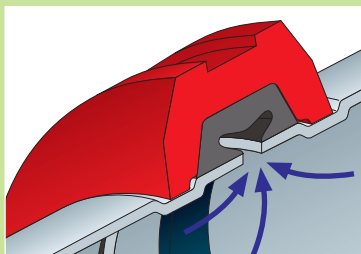

**Third seal**  
The system pressure or vacuum will then maximize the leak-tight seal.

## 1. Gaskets

Grade "E" EPDM with green color code identification conforms to ASTM D-2000 for service temperature from -34 °C (-30 °F) to 110 °C (230 °F). They are recommended for hot water not to exceed 110 °C (230 °F), plus a variety of dilute acids, oil free air and many chemical services. They are not recommended for petroleum services. For dry pipe and freezer systems a FlushSeal Grade "E" Gaskets with rigid couplings is recommended. Details for special gaskets, Grade "T" Nitrile, Grade "EN" EPDM (for potable water services), Grade "O" Fluoro Elastomer and Grade "L" Silicone, see pag. 38.

## 2. Coatings

All housings are standard coated with a lead-free water based enamel paint, color red. Hot dipped zinc galvanized, epoxy or other coatings are optional. For detailed information contact the sales office.

## 3. Bolts and Nuts

Coupling bolts and nuts are heat treated carbon steel, oval-neck track head bolts and heavy hex nuts, conforming to ASTM-A183 minimum tensile strength of 110,000 psi. Bolts and nuts are Zinc electroplated to ASTM B633. The oval neck design prevents turning off the bolt while tightening the hex nut with a single wrench. The metric bolts and nuts are made out of zinc electroplated carbon steel.



# GENERAL: THE QUICKLOCK SYSTEM

## Expansion and contraction

Quicklock Flexible couplings are able to absorb linear movement of the pipework due to temperature changes. This eliminates or minimises the need for expansion joints.

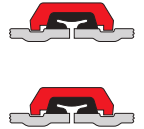

## Maintenance

The Quicklock Grooved System method allows for quick economical changes as necessary for field retrofit, with the ability to isolate equipment and piping systems for modifications and system repair.

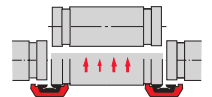

## Noise and vibration

The use of Quicklock couplings reduces noise and vibration in pipe systems.

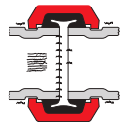

## Self restraining

The coupling housings are designed to engage into the grooves and provide a secure joint. The pipe ends are sealed by a pressure responsive gasket which is encapsulated by the ductile iron housing.

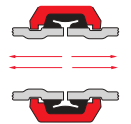

## Misalignment

The Quicklock flexible couplings will accommodate misalignments. The maximum deflection per coupling can be found in this catalogue.

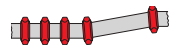

## Joint deflection

Quicklock flexible couplings are within reason able to absorb pipe deflection, for further details contact your sales office. This is a great advantage in tunnel, bridge and mine applications.



## Rigid Connection

The rigid couplings have a patented design that allows the coupling housings to grip along the full 360° of circumference of the pipe groove. This means a more rigid and stronger connection through a range of pipe tolerances. The coupling design eliminates distortion of the gasket as the housing sections come together.

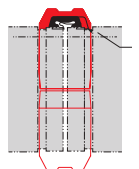

## Trouble Free Design

The patented universal tongue and groove design of the coupling housings assures trouble free installation. Potential misalignment of the coupling housings that could lead to a joint failure is a thing of the past.

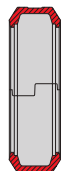

# ADVANTAGES OF QUICKLOCK: GROOVED PIPING PRODUCTS



Quicklock Grooved can reduce installation time for your piping by 50%.



Quicklock Grooved can be used in hazardous areas, without special precautions.



Quicklock Grooved reduce noise and vibration in pipe systems.



Quicklock Grooved only require wrenches for installation.

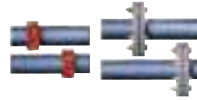

Quicklock Grooved require far less space than traditional flanged system.



Quicklock Grooved is a self restraining joint.



Quicklock Grooved reduce the cost of your installation.



Quicklock Grooved reduces welding contamination.

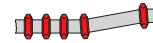

Quicklock Grooved will accommodate misalignment.



Flexibility to produce steel fittings able to meet client's needs.



Quicklock Grooved is healthy. It does not lead to hazardous fumes in working area.



Quicklock Grooved can absorb deflection to a certain value.



Quicklock Grooved is dependable; it is tested and approved by the major classification societies.



Quicklock Grooved is green. The products are made of 90% recycled materials.



Quicklock Grooved is a renowned quality product; it is manufactured according to the ISO 9001 QA standard.



Quicklock Grooved is safe, no hot work is required.



Quicklock Grooved is able to tolerate linear movement of the piping system.



Quicklock Grooved is not only a product, it provides a complete piping solution of couplings, fittings and valves

THE QUICKLOCK FITTINGS APPROVALS



✓ ISO 9001  
✓ approved products



**Note:** Not all products in this catalogue have all above mentioned approvals. For specific information on Mechanical and Fire Protection approvals and details on pressure ratings and listings please contact **Tubificio Lombardo S.r.l.**

## DISCLAIMER

Every effort has been made to ensure the accuracy of the information included in this catalogue. However, **Tubificio Lombardo** makes no express or implied warranty of any kind with respect to this information.

**Tubificio Lombardo** further accepts no responsibility or liability resulting from the use of the information contained herein.

# GENERAL: APPLICATIONS

## **Heating, ventilation and air conditioning The Comfort Factor**

Using Quicklock couplings and fittings in comfort piping systems combines a number of advantages. The ease and swiftness of installation reduces the actual time needed on the jobsite. Furthermore, any "on the spot" changes in the piping system can be handled with Quicklock system. An airduct where your heating line should be? Using some extra 45° elbows takes brings you around any obstacle. Even mistakes in prefab can be corrected easily. By loosening the bolts and nuts, fittings can be simply rotated in the required direction, prior to filling the system and pressurizing.

Quicklock flexible couplings can also take care of misalignment. These extra degrees of angular deflection help you to compensate when needed. Thermal expansion? The use of flexible couplings offers you a few millimetres of movement per coupling. When correctly designed, you can save on the use of expansion joints. The noise and vibration that is generated by pumps and chillers is reduced by Quicklock couplings.

So by using Quicklock grooved products you do a lot more than you think. Not only have you just connected pipe, you have taken care of thermal expansion and contraction, misalignment and noise reduction. Working in confined spaces all of a sudden has become very easy. No longer do you have to move heavy equipment, or be afraid of welding sparks creating potential fires. Now, all you need is the space to operate a wrench and you have done it in the fastest possible way. Saving time and money!



# GENERAL: APPLICATIONS

## **Tunnels, Bridges and Mines, Under and Over**

The construction of tunnels and bridges always requires a great deal of temporary piping. Piping needed to provide compressed air and water for drilling equipment. With Quicklock couplings and fittings, a quick method is offered to erect and dismantle great distances of piping with little time involved. Slurry drain lines to transport sand, rock and water are often concrete lined to prevent premature wear of the piping system.

By using Quicklock couplings, rotation of the pipework to ensure maximum use of the available lining has become very easy. Just loosening the bolts and nuts on two couplings offers the ability to rotate the pipe (never remove any piping components nor correct or modify any piping deficiencies without first depressurizing and draining the system).

In tunnels or on bridges, Quicklock grooved products are used for drainage, drinking water, compressed air and fire protection. Here, flexible couplings are used enabling the pipework to follow changes in direction and the general course of the tunnel or bridge.

In mining, safety is the number one issue. Quicklock grooved products can be installed without having to use welding equipment or torches in a potentially hazardous environment. Here too, flexible couplings offer the ability to follow the terrain, without having to use special fittings to compensate for misalignment. By loosening two couplings, pipe lines can be replaced or modified and segments can be added without increased down time.



**LIGHT. EFFICIENT.  
RELIABLE.**

# GENERAL: APPLICATIONS

## **Industrial Applications, Safety First!**

There are many reasons why Quicklock grooved products are so widely used in Industrial applications. One of the main reasons being that Quicklock couplings, fittings and valves can be installed without risk of fire or explosion.

When conducting maintenance, the down time for system cleaning or changes of pipework is reduced to a minimum. By removing two couplings, entire sections of pipe can be replaced or altered.

In abrasive systems where lined piping is used, the loosening of two couplings (in many cases just 4 bolts and nuts) enables the rotation of pipe segments. By then rotating the pipe 45° optimal use can be made of the remaining inner protection.

In tank storage areas, Quicklock grooved products are often used to compensate ground settlement. The use of a number of flexible couplings in line offers the ability to deal with vertical movement of the pipe lines.

Temporary pipe lines can be quickly installed and disconnected, providing an easy and secure solution.

Quicklock grooved products can be used with all carbon steel piping, including galvanized pipe.



# GENERAL: APPLICATIONS

## **Snow-Making, the Cold Facts**

In many ski resorts you will find Quicklock grooved products being used on the distribution piping feeding snow cannons. The advantages of quick installation, easy maintenance and most of all the ability to use flexible couplings that will follow the course of the terrain make Quicklock grooved products the "Number One Solution" for pipe connections. Whenever pipes are placed in trench it is imperative making the hydraulic test before covering the pipeline with soil.

## **Automotive, Mobility in Piping**

In the automotive industry Quicklock couplings are used on virtually all systems. In addition to the heating and air-conditioning systems, couplings, valves and fittings are used on compressed air lines, drain and process lines and for fire protection. Using Quicklock products greatly reduces down-time when systems need to be serviced etc.



# COUPLINGS, FITTINGS & FLANGES: MATERIAL SPECIFICATION

## Material specifications

Quicklock Grooved Products are manufactured in modern, state of the art ductile iron foundries. The following applicable material specifications for ductile iron, galvanizing and rubber-injection apply:

## Housing & fitting specifications

- ASTM A-536 - Standard specifications for Ductile Iron Castings Grade 65-45-12
- Tensile Strength, min. 65,000 psi
- Yield Strength, min. 45,000 psi
- Elongation in 2" or 50 mm, minimum 12%
- ASTM A-153 Standard Specification for Hot Dip Galvanizing

## Fabricated

Carbon steel according DIN/BS/ASTM Standard. ASTM A-153 or DIN EN10240 [Previous DIN2444] Standard Specification for Hot Dip Galvanizing

## Gasket specifications

Grade 'E' EPDM gaskets have a green color code identification and conform to ASTM D-2000 for service temperatures from -34 °C [-30 °F] to +110 °C [+230 °F]. They are recommended for hot water not to exceeding the +110 °C [+230 °F], plus a variety of dilute acids, oil free air and many chemical services. They are not recommended for petroleum services.

Grade 'T' Nitrile gaskets have a orange color code identification and conform to ASTM D-2000 for service temperatures from -29 °C [-20 °F] to +82 °C [+180 °F]. They are recommended for petroleum products, vegetable oils, mineral oils and air with oil vapors.

Grade 'EN' EPDM gaskets have a green/yellow color code identification and conform to ASTM D-2000 for service temperatures from -29 °C [-20 °F] to +90 °C [+193 °F]. They are DVGW/ACS/WRAS/ARPA approved and recommended for potable water services.

Grade 'O' Fluoro Elastomer gaskets have a blue color code identification and suitable for service temperatures from -29 °C [-20 °F] to +149 °C [+300 °F]. They are high temperature resistance to oxidizing acids, petroleum oils, hydraulic fluids, halogenated hydrocarbons and lubricants.

Grade 'L' Silicone is a red gasket and suitable for service temperatures from -34 °C [-30 °F] to +177 °C [+350 °F]. They are recommended for dry hot air and some high temperature chemical services.

## Bolt specifications

ANSI/Metric: Heat treated Carbon Steel Track Head Bolts conform to the physical properties of ASTM A-183 minimum Tensile Strength of 758,340 kPa (110,000 psi). Bolts and Nuts are zinc electroplated.

Paint Specifications:

Standard: • Red RAL3000      Optional: • Hot Dip Zinc Galvanized  
                  • Non Lead                                      • White RAL9010 Non Lead

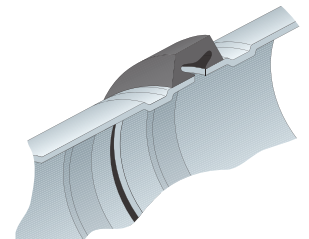

**Note:** All dimensions in this catalogue are nominal.

# DESIGN DATA: GASKETS

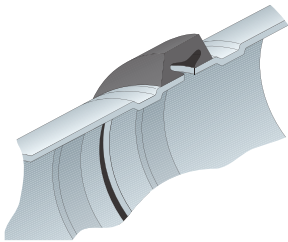

## Quicklock Gasket Grade Index and Recommendations

The Gasket Recommendation Tables have been developed to assure maximum service life. The tables have been developed from information supplied by the material manufacturers of the elastomer, technical reference literature and testing conducted by Tubificio Lombardo. In evaluating the gasket grade for intended service applications consideration must be given to the following: system operating temperature, fluid or solution concentration, and duration of service.

All gasket recommendations are based on a temperature of 21°C (70°F) unless otherwise noted. Tubificio Lombardo products should be consulted if combinations of service solutions are being considered. Contact Tubificio Lombardo for recommendations for services not listed.

Gasket recommendations apply to Quicklock gaskets only. These listings do not apply for Quicklock Butterfly Valves.

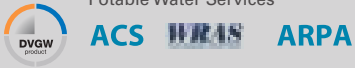
Grade	Temperature Range	Compound	Colour Code	General Service Application
E	-34°C to + 110°C (-30°F to +230°F)	EPDM	Green	Hot water, dilute acids, alkalis and many chemical services not involving petroleum products. Excellent oxidation resistance. NOT FOR USE WITH HYDROCARBONS
Flush seal	-34°C to + 110°C (-30°F to +230°F)	EPDM	Green	Hot water, dilute acids, alkalis and many chemical services not involving petroleum products. Excellent oxidation resistance. NOT FOR USE WITH HYDROCARBONS Recommended for low temperature and vacuum services
T	-29°C to + 82°C (-20°F to +180°F)	Nitrile (Buna-N)	Orange	Petroleum products, vegetable oils, mineral oils and air with oil vapors NOT RECOMMENDED FOR USE IN HOT WATER SYSTEMS NOT RECOMMENDED FOR HOT DRY AIR SYSTEMS
EN	-29°C to + 90°C (-20°F to +193°F)	EPDM	Green/Yellow	Potable Water Services 
O	-7°C to + 149°C (+20°F to +300°F)	Fluoro Elastomer	Blue	High temperature resistance to oxidizing acids, petroleum oils, hydraulic fluids, halogenated hydrocarbons and lubricants
L	-34°C to + 177°C (-30°F to +350°F)	Silicone	Red Gasket	Dry hot air and some high temperature chemical services

## Flush seal gasket



The FlushSeal Grade E gasket is used primarily for dry pipe fire protection systems, vacuum service, and freezer applications. The FlushSeal gasket differs from standard gaskets by closing off the gap of gasket cavity. This is accomplished by positioning the center "rib" of the gasket over the gap between the pipes. The FlushSeal gasket has two tapered sealing edges in addition to the center rib for additional strength and sealing. The FlushSeal gasket is available in sizes 32 mm to 300 mm. A petroleum-free silicone based lubricant is recommended for all dry pipe systems. For low temperature services or dry systems in cold storage or freezer applications, use FlushSeal gaskets. For vacuum services > 381 mm Hg, FlushSeal gaskets should be used for couplings in sizes 8" and above.

**Note:** Rigid couplings are preferred for vacuum, dry pipe and freezer applications.

# DESIGN DATA: GENERAL

## Rigid Joints

Quicklock Rigid Couplings provide rigid gripping of the pipe. They are designed to bring the pipe ends closely together and the coupling clamps firmly onto the pipe OD and also onto the bottom of the grooves. Because Rigid Couplings clamp around the entire pipe surface, they provide resistance to flexural and torsional loads and therefore permit longer spacing to ASME/ANSI B31.1 (Power Piping) and ASME/ANSI B39.1 (Building Services) requirements as well as NFPA 13 (Sprinkler Systems).



## Flexible Joints

Quicklock Flexible Couplings act as an "expansion joint", allowing linear and angular movement of the pipe. They are designed with the coupling keys engaging the pipe without gripping on the bottom of the grooves, while still providing for a restrained mechanical joint. This is particularly useful to allow for pipe expansion / contraction and piping misalignment.



### Linear Movement (Flexible Joints)

For thermal expansion the pipe ends at each joint should be fully gapped to the maximum end gap. This can be accomplished by pressurizing the system and then anchoring the system.

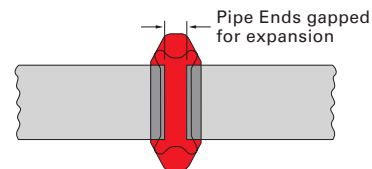

For thermal contraction with flexible couplings, the pipe ends at each joint should be fully butted. The system can then be anchored in place to prevent the pipe ends from opening up to the maximum end gap when pressurized.

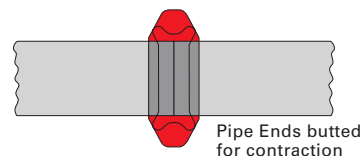

For design purposes, the maximum pipe end gap should be reduced to account for field practices as follows:

End Gap Reduction	
Pipe Size inches mm	Maximum Pipe End Gap Reduction
1 1/4 - 3 42,4 - 88,9	50%
4 - 24 114,3 - 609,6	25%

Therefore the following values should be used as available pipe end movements for Quicklock Flexible Couplings:

Pipe End Movements		
Pipe Size inches mm	Cut Grooved inches mm	Roll Grooved* inches mm
1 1/4 - 3 42,4 - 88,9	0 - 0,063 0 - 1,6	0 - 0,031 0 - 0,8
4 - 24 114,3 - 609,6	0 - 0,188 0 - 4,8	0 - 0,094 0 - 2,4

\* - Roll grooved joints provide 1/2 the available movement of cut grooved joints.

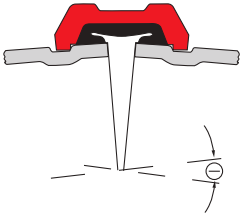

### Angular Deflection

Quicklock Flexible Couplings are capable of accommodating angular deflection.

The deflection published in our literature is a maximum value. For design purposes the maximum deflection should be reduced to account for field practices as shown:

Deflection	
Pipe Size inches mm	Maximum Pipe Deflection Reduction
1 1/4 - 3 42,4 - 88,9	50%
4 - 24 114,3 - 609,6	25%

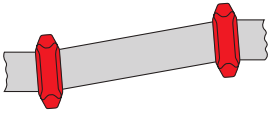

### Expansion / Contraction

Quicklock Flexible Couplings are capable of accommodating pipe thermal movements provided they are properly gapped and a sufficient quantity of flexible couplings are used. Note that flexible couplings will not accommodate both full maximum linear movement and the maximum available angular deflection concurrently at the same joint.

If it is desired to have both deflection and linear movement available, then the system should have sufficient flexible joints to accommodate the requirement.

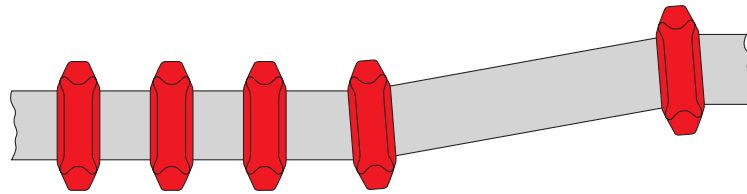

### Thermal Movement

The following guidelines are similar to any expansion joint: It is recommended that anchors be installed at changes of direction on the pipe lines to control the pipe movement. The thermal expansion/contraction in the piping system can be accommodated utilizing Quicklock Flexible Couplings.

In designing anchoring systems, it is suggested that the following be taken into consideration as a minimum:

- Pressure thrusts
- Frictional resistance of any guides or supports
- Centrifugal thrust due to velocity at changes of direction
- Activation force required to compress or expand a flexible coupling

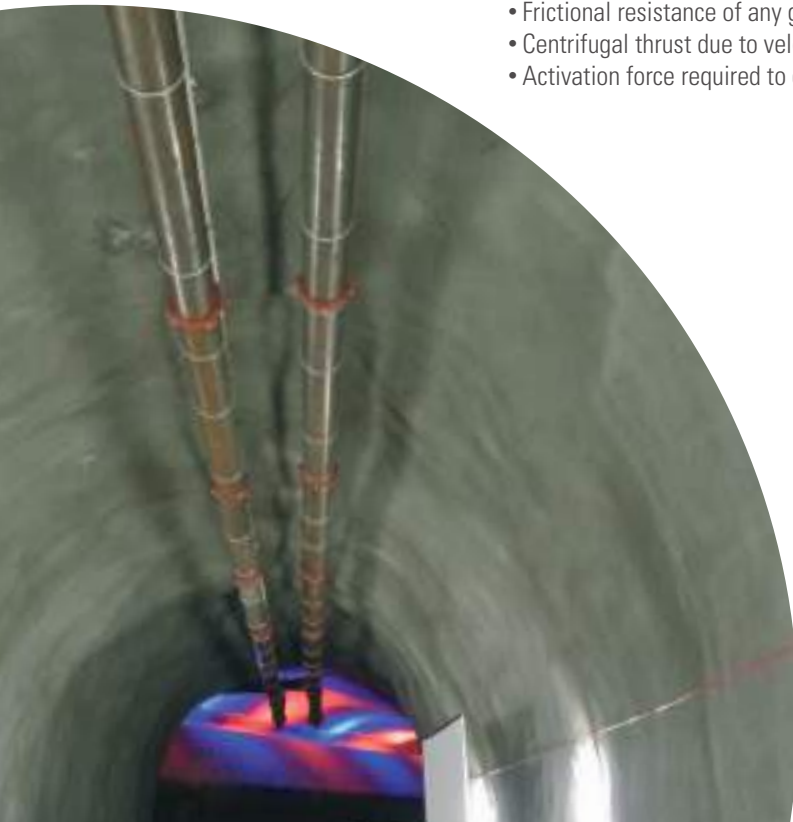

Activation Force	
Pipe Size inches mm	Activation Force Lbs. N
1 1/4 42,4	35 156
1 1/2 48,3	45 200
2 60,3	70 311
2 1/2 73,0	100 645
76,1	110 489
3 88,9	145 645
4 114,3	240 1068
5 139,7 / 141,3	375 1668
165,1	500 2224
6 168,3	520 2313
8 219,1	880 3914
10 273,0	1365 6072
12 323,9	1915 8518

Three methods are available as examples to accommodate thermal expansion/contraction:

1. Design the system with rigid couplings and place expansion joints at the relevant locations. Expansion joints may be a series of flexible grooved couplings of a sufficient quantity to accommodate the movement.
2. Design the system with flexible and/or rigid couplings and allow the pipe to move in directions desired, with the use of anchors and guides if so required. With this method, it is important to ensure that movement at branch connections, changes of direction, equipment hookup, etc., will not cause damage or excessive stresses.

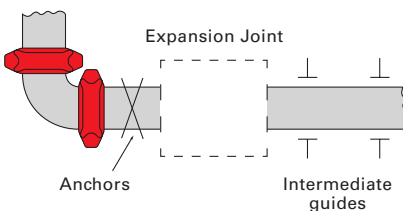

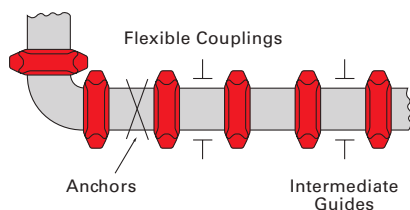

3. Design the system with flexible couplings utilizing the expansion/contraction capabilities of these products. The following example illustrates this method:
- 150 mm Schedule 40 Steel Pipe, Roll Grooved, 45,73 m long, anchored at each end.

Maximum Temperature = 93,3°C  
 Minimum Temperature = 4,4°C  
 Install Temperature = 26,7°C

- 3a. Thermal Expansion Utilizing the Thermal Expansion Table, the following calculations are performed:

- 3b. Allowance for installation temperature to the minimum temperature, in this case 26,7°C to 4,4°C is calculated as:

Steel expansion/contraction factor = 1,2 mm per m/100°C  
 $(26,7-4,4) \times 1,2/100 = 0,264$  mm/m

Total contraction: 0,264 mm/m x  
 45,73 m = 12,1 mm

- 3c. Allowance for installation temperature to the maximum temperature, in this case 26,7°C to 93,3°C is calculated as:

$(93,3-26,7) \times 1,2/100 = 0,8$  mm/m

Total expansion: 0,8 mm/m x  
 45,73 m = 36,56 mm

- 3d. Couplings Required Available linear movement for a 150 mm on roll grooved pipe = 2,4 mm per coupling, therefore the number of flexible Couplings required is:

#### Minimum Gap for Contraction Only

Installation temperature to minimum temperature:

$$\frac{12,1 \text{ mm}}{2,4 \text{ mm per coupling}} = 5,1$$

Use 6 flexible Couplings for pipe contraction with pipe ends fully butted together.



#### Maximum Gap for Expansion Only

Installation temperature to minimum temperature:

$$\frac{36,6 \text{ mm}}{2,4 \text{ mm per coupling}} = 15,3$$

Use 16 flexible Couplings for pipe expansion with pipe ends fully gapped apart.



ΔTemperature °C	mm / m	ΔTemperature °C	mm / m
-40	-0,48	50	0,60
-30	-0,36	60	0,72
-20	-0,24	70	0,84
-10	-0,12	80	0,96
0	0	90	1,08
10	0,12	100	1,20
20	0,24	110	1,32
30	0,36	120	1,44
40	0,48	130	1,56

#### Misalignment and Deflection

Quicklock flexible couplings provide for restrained joints and allow for deflection to aid where the pipe or equipments is misaligned.

Note that flexible couplings will not accommodate both full maximum linear movement and the maximum available angular deflection concurrently at the same joint.

If it is desired to have both deflection and linear movement available, then the system should have sufficient flexible joints to accommodate the requirement.

Flexible couplings are also useful in designing curved piping systems.

$$R = L / (2 \sin \theta / 2)$$

$$L = 2R \sin \theta / 2$$

$$N = T / \theta$$

N = Number of flexible couplings needed

R = Radius of curve

L = Pipe length

$\theta$  = Deflection from centerline, in degrees, for each coupling (see table)

T = Total deflection in degrees required

This table represents the design deflection for roll grooved pipe and incorporates the recommended safety factor reduction for field practices (50% for sizes 25 mm - 80 mm and 25% for sizes 100 mm - 600 mm).

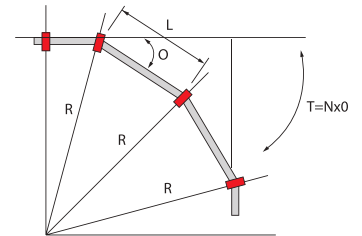
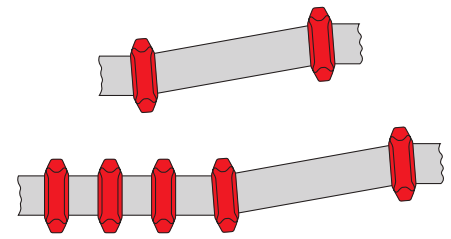

Deflection $\theta$ (Roll Grooved Pipe)	
Pipe Size inches mm	Degrees
1 1/4 42,4	1,08
1 1/2 48,3	0,94
2 60,3	0,75
2 1/2 73,0	0,62
76,1	0,60
3 88,9	0,51
4 114,3	1,19
5 139,7 / 141,3	0,97
165,1	0,83
6 168,3	0,81
8 219,1	0,63
10 273,0	0,50
12 323,9	0,42



# DESIGN DATA: GENERAL

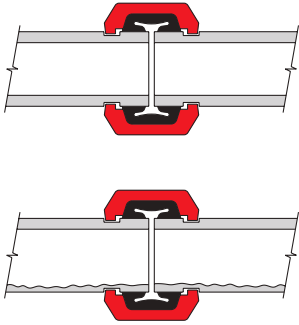

## Rotational Movement

Quicklock flexible couplings are suitable for use in seismic as well as mining applications. The inherent capability of the flexible coupling to allow for linear movement, angular deflection, and rotational movement, make it an excellent choice for reducing stresses in a piping system and to increase pipe life in slurry applications.

For mining applications where the pipe needs to be rotated, the system should be depressurized. The pipe couplings bolts/nuts can be loosened, pipe rotated and the bolts/nuts re-tightened and the system be put back in service.

Even distribution of pipe wear can be achieved with this method on the inner surface of the pipe.

**Note:** Precautions are necessary to monitor pipe wall thickness to evaluate pressure capability of the pipe with reduced wall.

## Linear Movement

Flexible couplings are designed with the couplings keys engaging the pipe without gripping on the bottom of the groove while still providing for a restrained mechanical joint.

The inherent flexibility of the coupling must be considered when deciding on support arrangements for the piping system as movement can occur in more than one plane (linear movement, angular deflection and rotational movement).

Upon system pressurization, each pipe end within the flexible couplings will expand to the maximum published value. The coupling keys make contact with the face of the groove and restrain the joint. In piping systems, this movement will be cumulative.

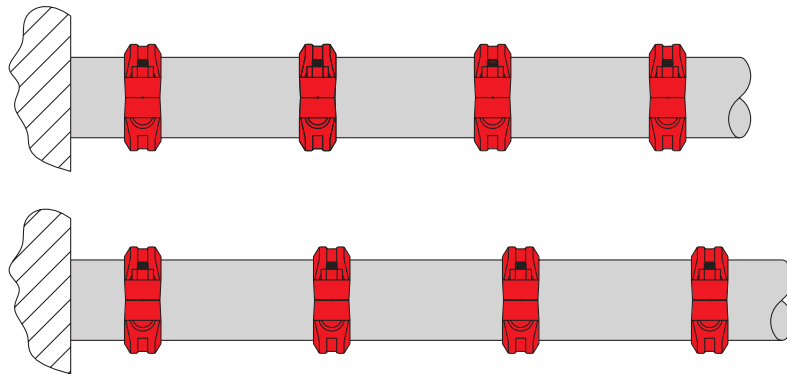

# DESIGN DATA: GENERAL

## Angular Movement

System movement can be accommodated by providing for sufficient offset lengths. Temperature increases/decreases can further increase this movement.

When systems are anchored with partially deflected joints, the system can move to the fully deflected condition upon pressurization resulting in the "snaking" of the piping system. Light weight hangers may not be suitable to prevent the lateral motion.

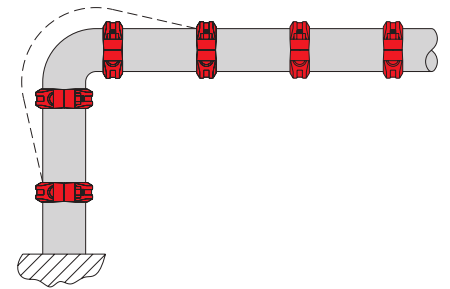
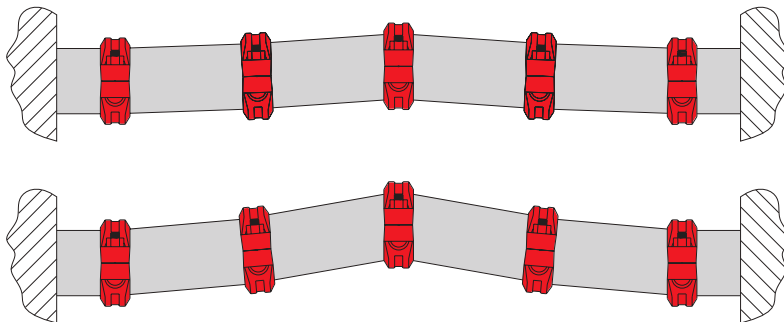

## Pipe Support

Pipe hanger positioning is important when considering pipe "sagging" due to the flexible nature of the piping system. Proper positioning of hangers at regions near the elbow, for example, should be considered. The use of spring hangers or other methods can be considered to accommodate vibrations.

Base supports, pressure thrust anchors and pipe offsets can be used to direct pipe movement. The use of rigid couplings can be considered to reduce the movement available with flexible couplings. Consideration to other methods of accommodation pipe movements may be required.

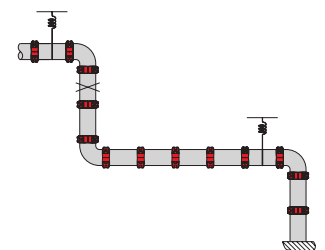
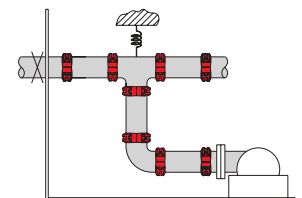
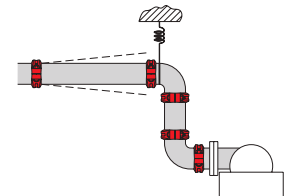
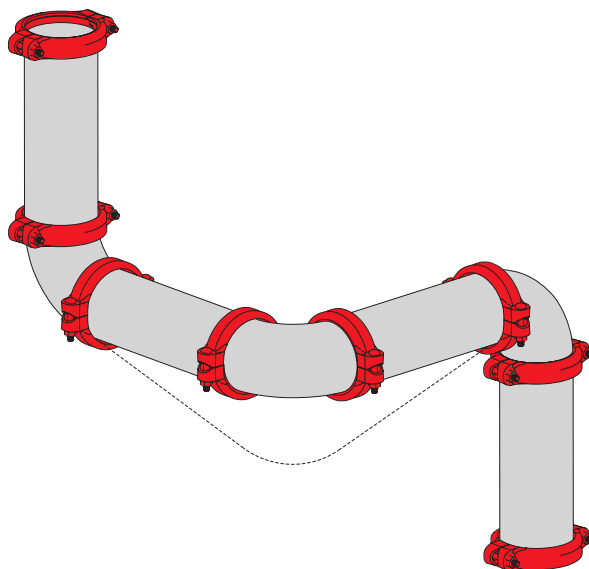

# DESIGN DATA: GENERAL

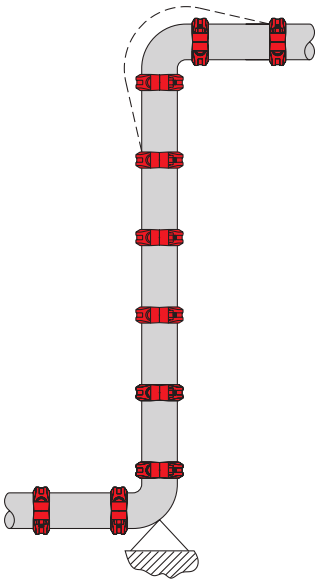

## Vertical Piping

Risers comprised of rigid couplings can be considered similar to welded or flanged systems. Where thermal movement exists, expansion joints and/or flexible couplings with offsets may be required.

When using flexible couplings, the movement that occurs in long lengths of piping needs to be considered. Each joint can move up to the maximum pipe end separation published. This movement can accumulate and result in the growth of the piping system, for example, at the top. Offsets may be necessary.

Should the riser contain branch connections, the movement which occurs at these locations with flexible couplings, will also need to be considered. One solution would be to anchor the vertical piping at appropriate locations to prevent movement which can cause stresses at the branches or equipment. The use of rigid couplings can be an advantage.

As always, good piping practice should prevail. It is the Designer's responsibility to select products suitable for the intended service and to ensure that pressure ratings and performance data is not exceeded. Never remove any piping component nor correct or modify any piping deficiencies without first depressurizing and draining the system. Material and gasket selection should be verified to be compatible for the specific application.

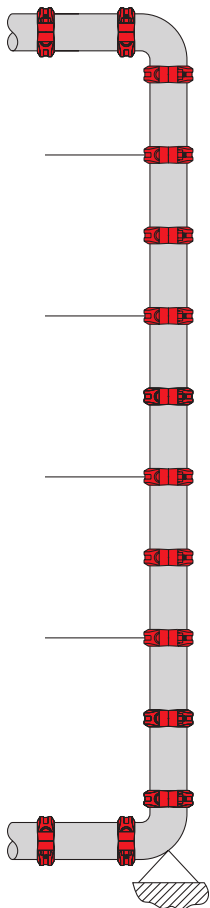

## Electric continuity

The Quicklock grooved couplings comply to the electric conductivity according to clause 11.1.2 of EN 61537:2007. Tests were performed by TÜV Rheinland® and test reports are available upon request.



Test pipe at TÜV Rheinland®

# INSTALLATION INSTRUCTIONS

## Installation / Assembly Instructions

Always read and understand the instructions. Never remove any piping component without verifying that the system is depressurizing and drained. Rigid Couplings with FlushSeal gaskets are preferred for dry pipe and freezer applications.

The following instructions apply to Couplings. The installation is based on pipe grooved in accordance with Standard Cut Groove or Roll Groove Specifications.



### Step 1

Inspect exterior groove and ends of the pipe to verify all loose debris, dirt, chips, paint and any other foreign material such as grease are removed. Pipe ends sealing surfaces must be free from projections, indentations, and/or other markings.



### Step 2

Verify that the coupling and gasket grade are correct for the application intended. Please refer to "Gasket" section of this catalogue for additional information. The edges and outer surfaces of the gasket should be covered with a fine layer of lubrication.

The edges and outer surfaces of the gasket should be covered with a fine layer of petroleum-free silicon lubricant or equivalent. Petroleum lubricant should not be used on Grade "E" "EPDM" gaskets to prevent deterioration of the gasket material. FlushSeal gaskets are recommended for freezer applications.



### Step 3

Install the gasket by placing the gasket over the pipe, which is to be fastened by the flexible coupling and ensure that the gasket lip does not extend beyond the end of the pipe.



### Step 4

Bring both pipe ends together, ensure proper alignment and slide the gasket into position, properly centering it between the grooved portions of each pipe.

**Note:** the gasket should not protrude into the grooves on either pipe segments or extend between the pipe ends.



### Step 5

With one nut and bolt removed, "swing around" as shown. Verify that the housings are over the gasket and that the housing keys are fully engaged into the grooves.



### Step 6

Insert the other bolt into the coupling and rotate the nuts until finger tight. Verify that the bolt heads are fully recessed in the housing.



### Step 7

Alternate between bolts when tightening nuts until properly torqued to bring housing in contact with the bolt pads. Note: uneven tightening can cause the gasket to pinch or bind.

“**QUALITY IS  
REMEMBERED  
LONG AFTER,  
PRICE IS  
FORGOTTEN**”



## **TUBIFICIO LOMBARDO**

**TUBIFICIO LOMBARDO srl**  
Via Papa Giovanni XXIII, 1  
46031 San Nicolò Po Mantova - ITALY  
Coordinates: N 45° 03' 02" - E 10° 50' 15"

tel. +39 0376 414131  
info@tubilomb.it  
[www.tubificiolombardo.it](http://www.tubificiolombardo.it)

